



VOLO • HIGH EFFICIENCY OZONE POWER SUPPLY

VL1800, VL2800 Series

Quick Guide

For safe use of this product, be sure to read the manual. In addition, please take good care of the manual and deliver it to the end-user.

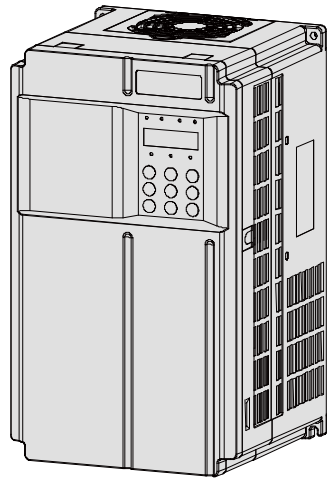

Quick Guide V1.2



Contents

01、 Safety Information and Precautions-----	1
02、 Product Information-----	5
03、 System Connection-----	9
04、 Installation and wiring-----	13
05、 Basic Operation -----	25
06、 List of parameters-----	29
07、 Fault diagnosis and exception handling-----	47
08、 Maintenance and upkeep-----	51
09、 Revision resume-----	53

Please Read This Important Information

Thank you for choosing the VL1800, VL2800 series ozone power supply designed and manufactured by Volo. At the same time, you will enjoy our comprehensive and sincere service for you. VOLO accepts no liability for any consequences resulting from negligent or incorrect installation or parameter adjustment of the Products. Please strict adherence to this instruction is required to ensure a high level of safety. If in doubt, please consult with VOLO or the Authorised Distributor.

01, Safety Information and Precautions

In this manual, there are three categories of security levels:



DANGER: indicates that failure to comply with the notice will result in severe personal injury or even death.



WARNING: indicates that failure to comply with the notice will result in personal injury or property damage.



ATTENTION: If the operation is wrong, it may result in moderate or minor injury, and equipment damage.

Please kindly be noted that these three kinds of mark relates to the safety. Any violation of these rules might lead to death or injury, damage of machine and its system. In addition, we will be not responsible for any personal hurt or damage of machine which is due to violation of principle mentioned in this manual.



Before installation

	<p>DANGER</p>	<ul style="list-style-type: none"> Do not install the equipment if you find water seepage, component missing or damage upon unpacking. Do not install the equipment if the packing list does not conform to the product you received. Do not touch the components with your hands. Failure to comply will result in static electricity damage.
	<p>WARNING</p>	<ul style="list-style-type: none"> When handling the ozone power supply, be sure to hold on to the shell. If you grab the front cover plate to carry the ozone power, the main body of the ozone power will fall, there is a risk of injury. Handle the equipment with care during transportation to prevent damage to the equipment. Do not use the equipment if any component is damaged or missing Failure to comply will result in personal injury. The device has been tested for withstand voltage before leaving the factory. No voltage withstand test can be carried out on any parts of the ozone power supply. And High Voltage may lead to ozone power insulation and internal device damage.



During installation

	<p>DANGER</p>	<ul style="list-style-type: none"> Do not loosen the fixed screws of the components, especially the screws with red mark. Refitting Ozone Power supply is strictly prohibited. The modified ozone power supply may pose a risk of electric shock. If your company or your company's customer has carried on the transformation to the product, our company will not assume any responsibility.
	<p>WARNING</p>	<ul style="list-style-type: none"> Do not install, maintain, inspect or replace parts unless you are an electrical professional. Or there's a risk of electrocution.
	<p>ATTENTION</p>	<ul style="list-style-type: none"> Use a shielded cable for the encoder, and ensure that the shielding layer is reliably grounded. Do not install transformers and other electromagnetic waves or interference devices in the ozone power supply around, otherwise it will lead to ozone power supply misoperation. If you need to install such equipment, should set shield plate between it and the ozone power supply.



At wiring

	DANGER	<ul style="list-style-type: none"> ● Do not operate the connection when the power is connected, otherwise there will be electric shock. Before checking, please cut off the power supply of all equipment. Even if the power supply is cut off, there is residual voltage in the internal capacitor. Please wait at least 10 minutes after power is cut off. ● The contact current of the ozone power supply is greater than 3.5 ma, please make sure that the ozone power supply is well grounded. There's a risk of electrocution.
	WARNING	<ul style="list-style-type: none"> ● Do not connect the power supply to the output terminal of the ozone power supply. Otherwise, it will cause the ozone power supply to be damaged, even may cause the fire. ● Some systems may operate mechanically when energized, and there is a risk of death or serious injury. ● Before connecting the ozone power supply, please make sure that the ozone power supply cover plate is firmly installed and the motor is allowed to restart. ● Before connecting the ozone power supply, please confirm whether the rated voltage of the ozone power supply is consistent with the power supply voltage. ● If the main circuit power supply voltage is used in error, there will be a fire risk. ● It is forbidden to connect the input power supply to the output terminals (U, V, W) of the ozone power supply. OTHERWISE CAUSE OZONE POWER DAMAGE! ● The brake resistance must not be directly connected to the DC bus (P +), (N -) terminals. Or there will be a fire!
	ATTENTION	<ul style="list-style-type: none"> ● When using ozone power supply, please follow the steps required by electrostatic prevention measures (ESD), otherwise it will damage the ozone power supply. ● Please follow the local standards, take certain branch, Short Circuit Protection Measures. If the protection measures are not appropriate, it may cause the ozone power supply to be damaged. ● The ozone power supply is suitable for short-circuit current below 100ka, the maximum voltage is 440VAC (400V class) circuit. ● Please do not share the ground wire with the welding machine or the power machine which needs high current, otherwise it will cause the ozone power source or the machine to act badly. ● When using more than one ozone power supply, take care not to make the ground wire into a loop. Otherwise, it will cause the Maloperation of the ozone power supply or the machine. ● Do not connect or operate if the machine is visibly damaged or parts are missing. ● The wiring, the inspection and so on please operate by the professional personnel.



After power-on

	DANGER	<ul style="list-style-type: none"> ● Do not open the cover plate when the power is on. OR YOU'LL GET ELECTROCUTED! ● Do not touch any input or output terminals of the ozone power supply. OR YOU'LL GET ELECTROCUTED! ● Please do not remove the ozone power supply cover or touch the printed circuit board, otherwise there will be the risk of electric shock.
	WARNING	<ul style="list-style-type: none"> ● If you need to confirm the parameter identification, please note that there is a risk of injury during the motor rotation. Otherwise, it could cause an accident! ● Do not change the ozone power supply manufacturer parameters. Otherwise it may cause damage to the equipment!

During operation

	DANGER	<ul style="list-style-type: none"> • Non-technical personnel should not detect the signal in operation. Otherwise, it may cause personal injury or equipment damage! • Do not touch the fan or the discharging resistor to check the temperature. Failure to comply will result in personal burnt.
	WARNING	<ul style="list-style-type: none"> • During the operation of the ozone power supply, no object is allowed to fall into the equipment. OTHERWISE CAUSE EQUIPMENT DAMAGE! • Do not use contactor on-off method to control the start and stop of ozone power supply. OTHERWISE CAUSE EQUIPMENT DAMAGE!

During maintenance

	DANGER	<ul style="list-style-type: none"> • Personnel without professional training are not allowed to carry out repair and maintenance of ozone power supply, otherwise cause personal injury or equipment damage! • Please do not carry on the repair and maintenance to the equipment with live electricity. OR YOU'LL GET ELECTROCUTED!! • carry on the ozone power supply maintenance and repair 10mins after cutting off the ozone power supply input power. Otherwise the residual charge on the capacitor will do harm to people! • Before carrying out the maintenance work on the ozone power supply, please ensure that the ozone power supply is safely disconnected from all the power supply. • All the pluggable components must be plugged or removed only after power-off. • After the replacement of ozone power supply must be set and check the parameters. • Please do not power up the damaged machine, otherwise it will enlarge the damage of the machine.
	WARNING	<ul style="list-style-type: none"> • The rotating electric motor will feed some electric energy back to the ozone power supply, which will cause the ozone power to be charged even when the electric motor stops and the power is cut off. Before carrying out the maintenance work on the ozone power supply, please ensure that the motor is safely disconnected from the ozone power supply.

Signs related to Ozone Power Supply Safety

	DANGER	<p>The ozone power supply has warning signs for use at the following locations. When using, be sure to follow the warning signs.</p> <ul style="list-style-type: none"> • Be sure to read the instructions before installation and operation, otherwise there will be electric shock danger! • Please do not remove the cover plate when the power is on and the power is cut off within 10 minutes! • For maintenance, inspection and wiring, please first cut off the input side and output side power supply, and then wait 10 minutes, until the power indicator completely extinguished, before allowing the operation.
--	---------------	---

Memo NO. _____

Date / /

02、Product Information

2.1 Type and Identification

Product Category: (Take 3-phase 2.2 kw ozone power supply with built-in Brake Unit as an example.)

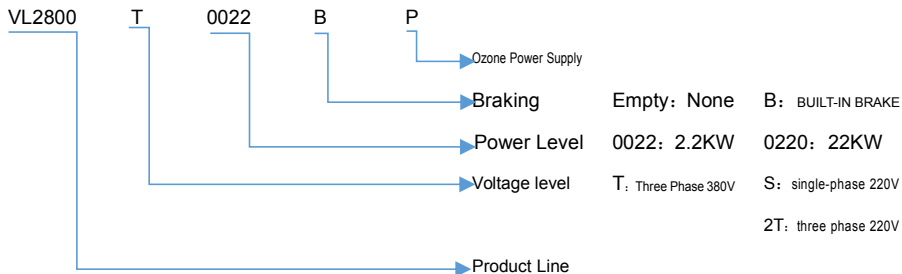

Product Nameplate (Take 3-phase 2.2 kw ozone power supply with built-in Brake Unit as an example.)

Model of Ozone Power Supply

Rated input

Rated output

Manufacture Number

MODEL :VL2800T0022GB/P

INPUT :AC3PH 380-480V 50Hz/60Hz

OUTPUT:AC2PH 0-540V 6.9A 2.2KW
0-10000Hz

SN :序列号



沃陆(上海)传动系统有限公司

Serial Number

COMPANY NAME

2.2 Product List

VL1800, VL2800 series of ozone power supply power range is 0.4 ~ 1100KW, the main information is shown in table 2-1. Configuration and installation dimensions of ozone power supply. Please refer to 4.1.3.

Form: 2-1 VL1800 SERIES PRODUCT LIST

SINGLE-PHASE POWER SUPPLY: 220V,50Hz/60Hz				
Model Number	Rated output current (A)	Structural Code	Power Supply (KW)	Frequency Range (KHz)
VL1800S0004GB/P	5.5	A1	0.4	0.2-10
VL1800S0007GB/P	7	A1	0.75	0.2-10
VL1800S0015GB/P	10	A1	1.5	0.2-10
VL1800S0022GB/P	13	A1	2.2	0.2-10

Form:2-2 VL2800 SERIES PRODUCT LIST



SINGLE-PHASE POWER SUPPLY: 220V,50Hz/60Hz				
Model Number	Rated output current (A)	Structural Code	Power Supply (KW)	Frequency Range (KHz)
VL2800S0004GB/P	5.5	D1	0.4	0.2-10
VL2800S0007GB/P	9	D1	0.75	0.2-8
VL2800S0015GB/P	13	D1	1.5	0.2-8
VL2800S0022GB/P	13	D2	2.2	0.2-8
VL2800S0030GB/P	17	D2	3	0.2-8
VL2800S0040GB/P	25	D2	3.7	0.2-8
VL2800S0055GB/P	32	D2	5.5	0.2-8
VL2800S0075GB/P	45	D3	7.5	0.2-8
VL2800S0110GB/P	60	D4	11	0.2-8
VL2800S0150GB/P	75	D4	15	0.2-8
VL2800S0185GB/P	91	D4	18.5	0.2-8
VL2800S0220G/P	112	D5	22	0.2-8
VL2800S0300G/P	150	D5	30	0.2-8
VL2800S0370G/P	176	D5	37	0.2-4
VL2800S0450G/P	210	D6	45	0.2-4
VL2800S0550G/P	304	D6	55	0.2-4
VL2800S0750G/P	350	D7	75	0.2-4
VL2800S0900G/P	380	D7	90	0.2-4

THREE-PHASE POWER SUPPLY: 220V,50Hz/60Hz				
Model Number	Rated output current (A)	Structural Code	Power Supply (KW)	Frequency Range (KHz)
VL28002T0004GB/P	5.5	D1	0.4	0.2-10
VL28002T0007GB/P	9	D1	0.75	0.2-8
VL28002T0015GB/P	13	D1	1.5	0.2-8
VL28002T0022GB/P	13	D2	2.2	0.2-8
VL28002T0030GB/P	17	D2	3	0.2-8
VL28002T0040GB/P	25	D2	3.7	0.2-8
VL28002T0055GB/P	32	D2	5.5	0.2-8
VL28002T0075GB/P	45	D3	7.5	0.2-8
VL28002T0110GB/P	60	D4	11	0.2-8
VL28002T0150GB/P	75	D4	15	0.2-8
VL28002T0185GB/P	91	D4	18.5	0.2-8
VL28002T0220G/P	112	D5	22	0.2-8
VL28002T0300G/P	150	D5	30	0.2-8
VL28002T0370G/P	176	D5	37	0.2-4
VL28002T0450G/P	210	D6	45	0.2-4
VL28002T0550G/P	304	D6	55	0.2-4
VL28002T0750G/P	350	D7	75	0.2-4
VL28002T0900G/P	380	D7	90	0.2-4

THREE-PHASE POWER SUPPLY: 380V,50Hz/60Hz				
Model Number	Rated output current (A)	Structural Code	Power Supply (KW)	Frequency Range (KHz)
VL2800T0004GB/P	2.5	D1	0.4	0.2-10
VL2800T0007GB/P	3.7	D1	0.75	0.2-10
VL2800T0015GB/P	5.5	D1	1.5	0.2-10
VL2800T0022GB/P	6.9	D1	2.2	0.2-8
VL2800T0030GB/P	9	D1	3	0.2-8
VL2800T0040GB/P	13	D1	3.7	0.2-8
VL2800T0055GB/P	17	D2	5.5	0.2-8
VL2800T0075GB/P	25	D2	7.5	0.2-8
VL2800T0110GB/P	32	D2	11	0.2-8
VL2800T0150GB/P	37	D3	15	0.2-8
VL2800T0185GB/P	45	D3	18.5	0.2-8
VL2800T0220GB/P	60	D4	22	0.2-8
VL2800T0300GB/P	75	D4	30	0.2-8
VL2800T0370GB/P	91	D4	37	0.2-8
VL2800T0450G/P	112	D5	45	0.2-8
VL2800T0550G/P	150	D5	55	0.2-8
VL2800T0750G/P	176	D5	75	0.2-4
VL2800T0900G/P	210	D6	90	0.2-4
VL2800T1100G/P	253	D6	110	0.2-4
VL2800T1320G/P	304	D6	132	0.2-4
VL2800T1600G/P	350	D7	160	0.2-4
VL2800T1850G/P	380	D7	185	0.2-4
VL2800T2000G/P	426	D7	200	0.2-4
VL2800T2200G/P	470	D8	220	0.2-4
VL2800T2500G/P	520	D8	250	0.2-4
VL2800T2800G/P	600	D8	280	0.2-2
VL2800T3150G/P	650	D8	315	0.2-2
VL2800T3550G/P	730	D9	355	0.2-2
VL2800T4000G/P	850	D9	400	0.2-2
VL2800T4500G/P	950	D9	450	0.2-2
VL2800T5600G/P	1160	D9	560	0.2-2
VL2800T6300G/P	1300	D10	630	0.2-2
VL2800T7100G/P	1450	D10	710	0.2-2
VL2800T8000G/P	1550	D11	800	0.2-2
VL2800T9000G/P	1700	D11	900	0.2-2
VL2800T10000G/P	1900	D11	1000	0.2-2
VL2800T11000G/P	2000	D11	1100	0.2-2

03、System Connection

3.1 Safety Information and Precautions

Safety Information and Precautions		
	<p style="color: red;">Danger</p>	<ul style="list-style-type: none"> ● It is forbidden to connect the power supply when the power supply is turned on. Or there's a risk of electrocution. Be Sure to keep the breaker OFF.
	<p style="color: red;">Warning</p>	<ul style="list-style-type: none"> ● When an ozone power supply is installed in a closed cabinet or other closed environment, adequate cooling, such as cooling fans or air conditioners, must be used to ensure that the inlet temperature of the ozone power supply is kept below 50 ° C, otherwise it will lead to overheating or fire.
	<p style="color: red;">Attention</p>	<ul style="list-style-type: none"> ● During the installation, please cover the upper part of the ozone power supply with cloth or paper to prevent metal chips, oil, water and so on from entering the inner part of the ozone power supply. ● If the foreign matter enters the ozone power supply, may cause the ozone power supply breakdown. ● Please take off the cloth or paper when the work is finished. If continue to cover on the top, it will make the poor ventilation, resulting in abnormal heat ozone power. ● When operating the ozone power supply, please follow the steps required by electrostatic prevention measures (ESD) , otherwise the inner circuit of the ozone power supply will be damaged by static electricity. ● Do not remove the hood of the State of the ozone power supply hanging, otherwise may cause ozone power circuit board or terminal row damage.

3.2 System Connection Diagram

When ozone power supply is used to make ozone system, it is necessary to install all kinds of electrical components on the input and output side of ozone power supply to ensure the safety and stability of the system.

THREE-PHASE 380V ~ 480V 45kW and above product systems are constructed as follows:

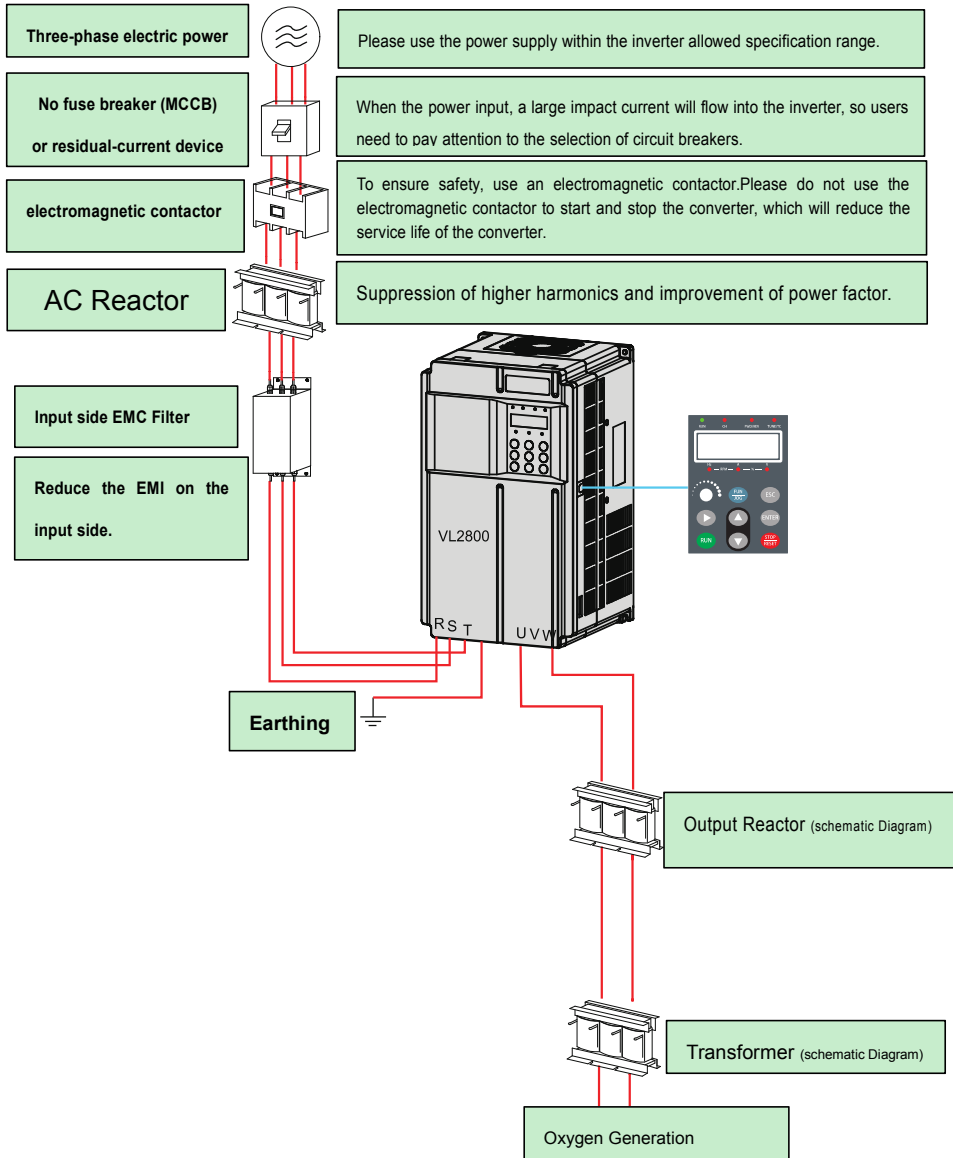

Composition diagram of power supply for ozone production system

3.3 DESCRIPTION OF SYSTEM COMPOSITION

Form: 3-1 Operating instructions for the peripheral electrical components of the Ozone Power Supply System.

Name of accessories	Mounting Position	Function description
Circuit Breaker	Between the input side of the power supply and the Ozone Power Supply.	Short Circuit Breaker: cut off the power supply when the downstream equipment overflows to prevent accidents.
		Earth Leakage Protection Circuit Breaker: High frequency leakage current may be produced when ozone power supply is working. In order to prevent electric shock and electric fire, please select and install appropriate leakage protection circuit breaker according to the situation on site.
(electromagnetic) CONTACTOR	Between the breaker and the input side of the Ozone Power Supply.	Power-on and power-off operation of ozone power supply should avoid frequent up-down operation (interval time is not less than one hour) or direct start operation of ozone power supply through contactor.
Input Reactor	Input side of Ozone Power Supply.	Increasing the power factor of the input side; Effectively eliminate the input side of the higher harmonic, to prevent voltage waveform distortion caused by other equipment damage; Eliminate the unbalance of input current caused by the unbalance between power supply phases.
EMC Filter	Input side of Ozone Power Supply.	Reduce the external conduction and radiation interference of Ozone Power Supply; Reduce the conduction interference from the power supply to the ozone power supply, improve the anti-interference ability of the ozone power supply.
direct current reactor	Between the emc filter and the brake resistance;	Increasing the power factor of the input side; Improve the efficiency and thermal stability of Ozone Power Supply; It can effectively eliminate the influence of higher harmonic on the input side of the ozone power supply and reduce the external conduction and radiation interference.
Output Reactor	Between the ozone power supply output side and the high voltage package, install close to the ozone power supply.	If necessary, the output reactor can be installed or not.
Transformer	Output side of Ozone Power Supply.	Please select the suitable transformer.

04、 Installation and Wiring

4.1 Installation

4.1.1 Installation Environment

- 1) Ambient Temperature: Ambient temperature has a great effect on the lifetime of Ozone Power Supply, The operating environment temperature of the ozone power supply is not allowed to exceed the allowable temperature range ($-10^{\circ}\text{C} \sim 50^{\circ}\text{C}$).
- 2) The ozone power supply is mounted on the surface of the flame-retardant Object. There should be enough space around to dissipate the heat. Ozone power supply is easy to produce a lot of heat when it works. And it is mounted vertically with screws on the mounting support.
- 3) Please install in a non-vibrating place. Vibration should not be greater than 0.6 G.
- 4) Do not install in direct sunlight, wet, water places.
- 5) Do not install in the air has corrosive, flammable, explosive gas places.
- 6) Do not install in oil, dust places.
- 7) Ozone power supply is the product installed in the cabinet, need to be installed in the final system for use, the final system shall provide the corresponding fireproof enclosure, electrical protective enclosure and mechanical protective enclosure, etc. And comply with the local laws and regulations and related IEC standard requirements.

4.1.2 Direction and space of installation

In order to help the ozone power source to dissipate heat, to install the ozone power supply in the vertical direction (figure 4-1). And ensure that the surrounding ventilation space. Table 4-1 shows the gap size for the ozone power supply installation (recommended value).

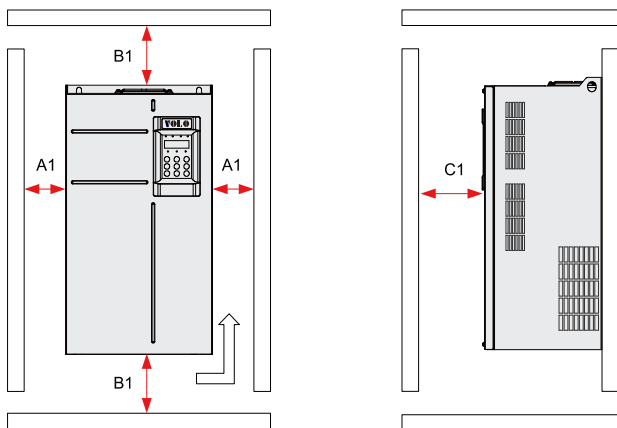

Picture 4-1 Schematic diagram of installation space

Form 4-1 Installation Space Requirement

Power Level	Size requirement (unit:mm)		
0.4kW~18.5kW	A1≥10	B1≥200	C1≥40
22kW~75kW	A1≥50	B1≥200	C1≥40
90kW~1100kW	A1≥50	B1≥300	C1≥40

4.1.3 External dimensions and mounting dimensions

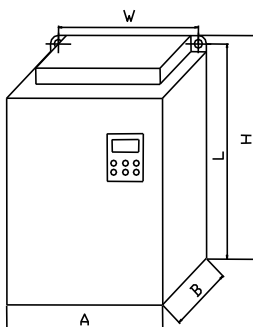

Picture 4-2-A Outline size and installation size (schematic diagram)

Form 4-2 VL1800 series product size list

Structure Code Name	Ozone Power Supply Series	External Dimension(mm)			Installation dimension(mm)		Installs Screw	Weight (kg)	remarks
		A	B	H	W	L			
A1	VL1800	102	150	170	90	158	M4	1.1	Plastic shell hanging type

Form 4-3 VL2800 series product size list (single phase / three phase 200V class)

Structure Code Name	Power Section of Ozone Power Supply	External Dimension (mm)			Installation dimension(mm)		Installs Screw	Weight (kg)	remarks
		A	B	H	W	L			
D1	0.4KW~1.5KW	125	166	186	114	172	M4	1.1	Plastic shell hanging type
D2	2.2KW~5.5KW	160	186	248	149	237	M4	2.5	
D3	7.5KW	208	194	322	190	304	M6	6.5	
D4	11KW~18.5KW	280	210	436	200	425	M6	20	Metal hanging type
D5	22KW~37KW	385	265	600	260	580	M8	32	
D6	45KW~55KW	473	307	700	343	678	M12	47	
D7	75KW~90KW	500	359	860	400	840	M12	90	
D8	110KW~132KW	660	370	1160	400	1139.5	M12	130	

Form 4-4 VL2800 series product size list (3-phase 400V class)

Structure Code Name	Power Section of Ozone Power Supply	External Dimension (mm)			Installation dimension(mm)		Installs Screw	Weight (kg)	remarks	
		A	B	H	W	L				
D1	0.4KW~4KW	125	166	186	114	172	M4	1.1	Plastic shell hanging type	
D2	5.5KW~11KW	160	186	248	149	237	M4	2.5		
D3	15KW~18.5KW	208	194	322	190	304	M6	6.5		
D4	22KW~37KW	280	210	436	200	425	M6	20	Metal hanging type. Please refer to the drawing of the machine Case.	
D5	45KW~75KW	385	265	600	260	580	M8	32		
D6	90KW~132KW	473	307	700	343	678	M12	47		
D7	160KW~200KW	500	359	860	400	840	M12	90		
D8	220KW~315KW	660	370	1160	400	1139.5	M12	130		
D9	355KW~560KW	700	432	1340	400	1309	M12	200		
D10	630KW~1000KW	830	510	1180	600	1240	M12	240		
D11	-	-	-	-	-	-	-	-		
C1	-	-	-	-	-	-	-	-		METAL CABINET TYPE Please refer to the drawing of the machine Case.
C2	-	-	-	-	-	-	-	-		
C3	-	-	-	-	-	-	-	-		

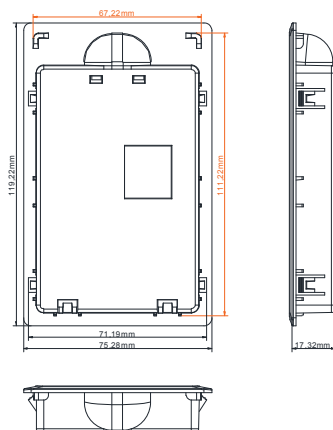

Picture 4-2-B External dimensions and mounting dimensions of VL1800 external panel brackets [schematic diagram (TJ1)]

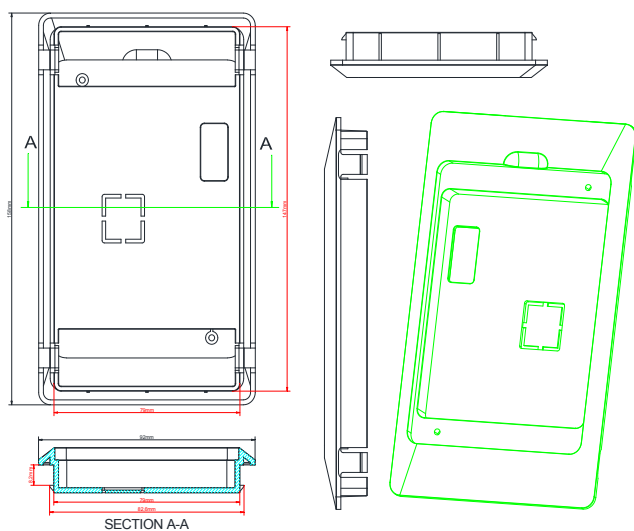

Picture 4-2-C Outline dimensions and mounting dimensions of VL2800 external panel (TJ2)

Form 4-4 Outline dimensions list of VL1800、 VL2800 series external keypad

Structure Code Name	Name	Opening Hole Dimensions(mm)			installation dimension(mm)		Installs Screw	Weight (kg)	remarks
		A	B	H	W	L			
TJ1	VL1800External Panel Bracket	75.28	17.32	119.22	67.5	111.5	-	-	
TJ2	VL2800External Panel	92	8.2 or 2	158	79	147	-	-	

4.2 Wiring

4.2.1 Standard wiring diagram

The following diagram is the VL2800 series 3-phase 380V voltage class 45kW ~ 1100kW model wiring diagram, other specifications refer to the following section explanation.

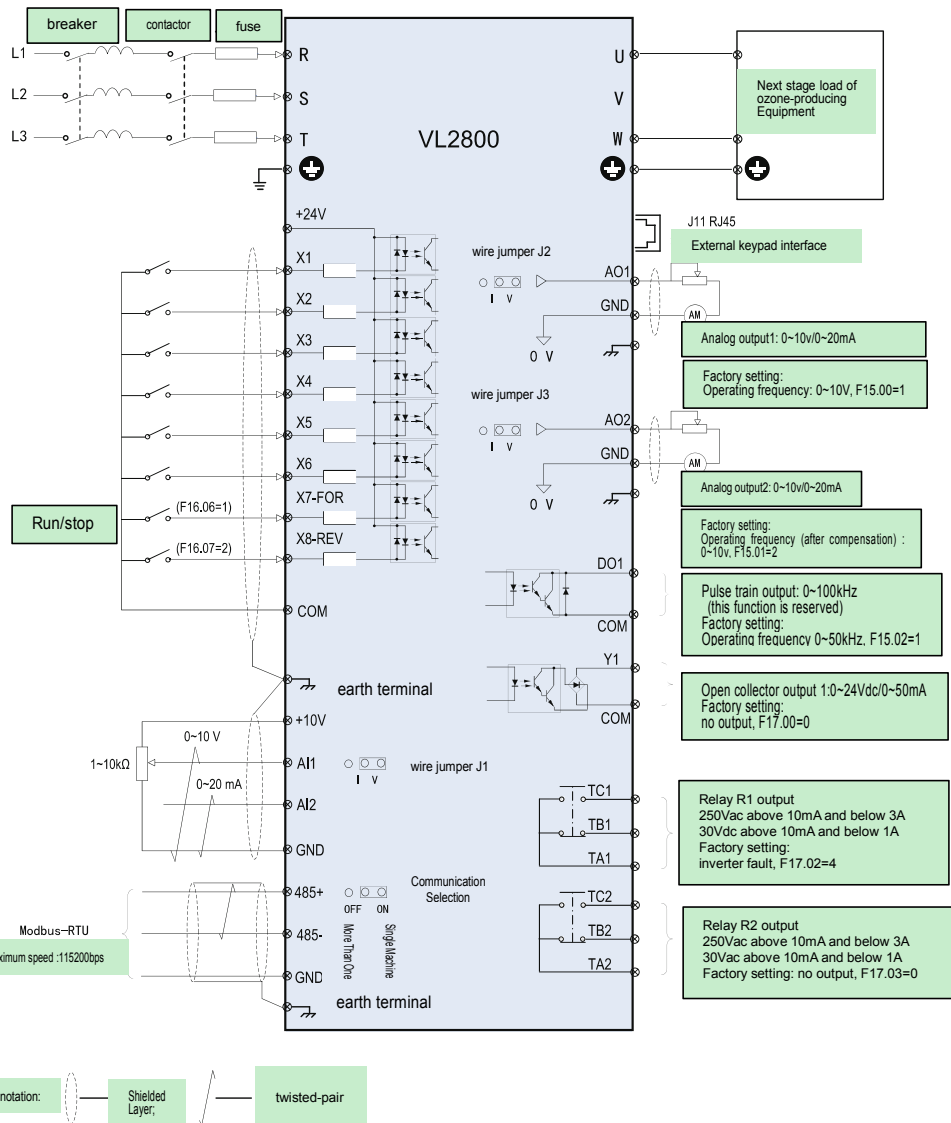

Picture 4-3 Typical wiring diagram of three-phase 380 ~ 480V

4.2.2 Main Circuit Power Terminal

Form 4-4 Main Circuit Terminal Specification

Terminal Marking	Terminal Name	Function description
R、S、T or L1、L2、L3	Power input terminal	AC input three-phase power connection point.
P+、N-或 P-	DC bus positive and negative terminals.	Input point of common DC bus, connecting point of External Brake Unit.
P+、PB	Brake resistance connection terminal.	Brake Resistance Connection Point
P+、P(P1)	DC reactor terminal	External DC reactor (or short connection)
U、V、W	Ozone Power Supply Output Terminal	connected load
	Earthing terminal (PE)	protective earthing

Wiring instructions of different specifications

Form 4-4 VL1800 single-phase 220V ozone power supply wiring instructions

Terminal Marking	Terminal Name	Function description
L1、L2	220V Power input terminal	AC input single-phase power connection point
P+、P(P1)	DC reactor terminal	External DC reactor (or short connection)
U、V	Ozone Power Supply Output Terminal	connected load
	Earthing terminal (PE)	protective earthing

Form 4-5 VL2800 single-phase 220V ozone power supply wiring instructions

Terminal Marking	Terminal Name	Function description
R、T	220V Power input terminal	AC input single-phase power connection point
P+、P(P1)	DC reactor terminal	External DC reactor (or short connection)
V、W	Ozone Power Supply Output Terminal 18.5 kw or less	connected load
U、W	Ozone Power Supply Output Terminal 22 KW and above	connected load
	Earthing terminal (PE)	protective earthing

Form 4-5 VL2800 three-phase 220V ozone power supply wiring instructions

Terminal Marking	Terminal Name	Function description
R、S、T	220V Power input terminal	AC input single-phase power connection point
P+、P(P1)	DC reactor terminal	External DC reactor (or short connection)
V、W	Ozone Power Supply Output Terminal 18.5 kw or less	connected load
U、W	Ozone Power Supply Output Terminal 22 KW and above	protective earthing
	Earthing terminal (PE)	protective earthing

Form 4-5 VL2800 three-phase 380V ozone power supply wiring instructions

Terminal Marking	Terminal Name	Function description
R, S, T	380V Power input terminal	Ac input three-phase power supply connection point
P+, P(P1)	DC reactor terminal	External DC reactor (or short connection)
V, W	Ozone Power Supply Output Terminal 37KW or less	connected load
U, W	Ozone Power Supply Output Terminal 45KW and above	connected load
	Earthing terminal (PE)	protective earthing

4.2.3 Guide for selection of peripheral electrical components

Form 4-5 Guide for selection of peripheral electrical components for Ozone Power Supply

SINGLE-PHASE POWER SUPPLY: 220V,50Hz/60Hz

Model	Breaker (A)	contactor (A)	Input side main circuit conductor (mm ²)	Output Side Main Circuit Conductor (mm ²)	Control loop conductor (mm ²)
VL2800S0004GB/P	10	9	0.75	0.75	0.5
VL2800S0007GB/P	16	12	0.75	0.75	0.5
VL2800S0015GB/P	25	18	1.5	1.5	0.5
VL2800S0022GB/P	32	25	2.5	2.5	0.5

Three phase power supply: 220V, 50 Hz 60 HZ

Model	Breaker (A)	contactor (A)	Input side main circuit conductor (mm ²)	Output Side Main Circuit Conductor (mm ²)	Control loop conductor (mm ²)
VL28002T0004GB/P	6	9	0.75	0.75	0.5
VL28002T0007GB/P	10	9	0.75	0.75	0.5
VL28002T0015GB/P	10	9	0.75	0.75	0.5
VL28002T0022GB/P	16	12	1.5	1.5	0.5
VL28002T0030GB/P	20	18	2.5	2.5	0.75
VL28002T0040GB/P	20	18	2.5	2.5	0.75
VL28002T0055GB/P	40	32	4	4	0.75
VL28002T0075GB/P	50	38	6	6	0.75
VL28002T0110GB/P	63	50	10	10	0.75
VL28002T0150GB/P	100	65	16	16	0.75
VL28002T0185GB/P	100	80	25	25	1
VL28002T0220GB/P	125	95	35	35	1
VL28002T0300GB/P	160	115	50	50	1
VL28002T0370GB/P	225	170	70	70	1
VL28002T0450GB/P	250	205	95	95	1
VL28002T0550GB/P	315	245	120	120	1
VL28002T0750GB/P	500	300	150	150	1
VL28002T0900GB/P	500	350	170	170	1

Three phase power supply: 380V, 50 Hz 60 HZ

Model	Breaker (A)	contactor (A)	Input side main circuit conductor (mm ²)	Output Side Main Circuit Conductor (mm ²)	Control loop conductor (mm ²)
VL2800T0004GB/P	6	9	0.75	0.75	0.5
VL2800T0007GB/P	6	9	0.75	0.75	0.5
VL2800T0015GB/P	10	9	0.75	0.75	0.5
VL2800T0022GB/P	10	9	0.75	0.75	0.5
VL2800T0030GB/P	16	12	1.5	1.5	0.5
VL2800T0040GB/P	16	12	1.5	1.5	0.5
VL2800T0055GB/P	20	18	2.5	2.5	0.75
VL2800T0075GB/P	32	25	4	4	0.75
VL2800T0110GB/P	40	32	4	4	0.75
VL2800T0150GB/P	50	38	6	6	0.75
VL2800T0185GB/P	50	40	10	10	1
VL2800T0220GB/P	63	50	10	10	1
VL2800T0300GB/P	100	65	16	16	1
VL2800T0370GB/P	100	80	25	25	1
VL2800T0450G/P	125	95	35	35	1
VL2800T0550G/P	160	115	50	50	1
VL2800T0750G/P	225	170	70	70	1
VL2800T0900G/P	250	205	95	95	1
VL2800T1100G/P	315	245	120	120	1
VL2800T1320G/P	350	300	120	120	1
VL2800T1600G/P	400	300	150	150	1
VL2800T1850G/P	450	350	170	170	1
VL2800T2000G/P	500	410	185	185	1
VL2800T2200G/P	630	475	240	240	1
VL2800T2500G/P	630	475	2×120	2×120	1
VL2800T2800G/P	700	620	2×120	2×120	1
VL2800T3150G/P	800	620	2×150	2×150	1
VL2800T3550G/P	1000	800	2×185	2×185	1
VL2800T4000G/P	1250	800	2×240	2×240	1
VL2800T4500G/P	1250	1000	2×240	2×240	1
VL2800T5600G/P	1500	1200	2×260	2×260	1
VL2800T6300G/P	1500	1200	2×260	2×260	1
VL2800T7100G/P	1800	1500	2×260	2×260	1
VL2800T9000G/P	1800	1500	2×260	2×260	1
VL2800T10000G/P	2000	1700	2×280	2×280	1
VL2800T11000G/P	2000	1700	2×280	2×280	1

4.2.4 Control loop terminal distribution.

◆ Control loop terminal layout.

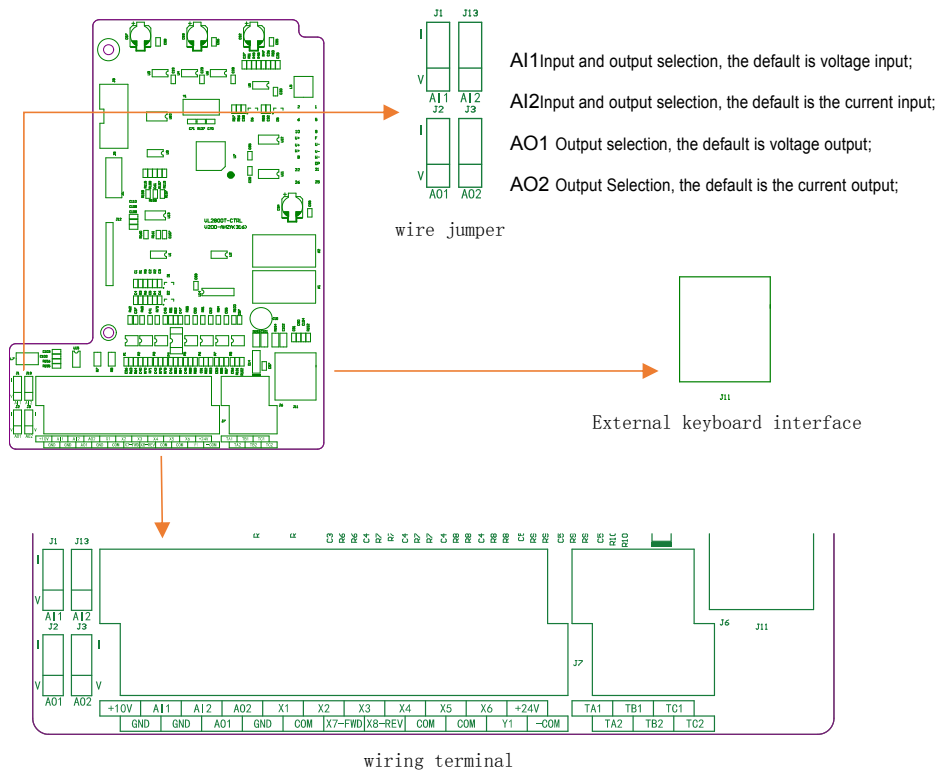

Picture 4-4 Terminal Layout of Control Circuit

Note: Due to different specifications or product upgrades, the control loop terminal may be different from the actual product, please refer to the actual product.

Form 4-6 VL2800 series Ozone Power Control Terminal function description.

Categories	Terminal Symbol	Terminal Name	Function description
Power Supply	+10V - GND	External Connection + 10V Power Supply	Provide +10V power to the outside, Maximum output current: 10mA. Generally used as an external potentiometer power supply, Resistance range of potentiometer: 1k Ω ~10k Ω .
	+24V - COM	External Connection +24V Power Supply	Provide +24V power supply to the outside, generally used as the working power supply of digital input and output terminals and the maximum output current of external sensor power supply: 200mA.
Analog Input	AI -GND	Analog Input 1	Input Range: 0Vdc~10Vdc/0mA~20mA, by the control panel J 1, J13 jumper selection decision. Input Impedance: Voltage Input 22k Ω , current input 500 Ω .
	AI2 -GND	Analog Input 2	
Digital Input	X1 -COM	Digital Input 1	Switching Input of Optical coupling isolation Input impedance: 1.39 k Ω
	X2 -COM	Digital Input 2	
	X3 - COM	Digital Input 3	
	X5 - COM	Digital Input 5	
	X6 - COM	Digital Input 6	
	X7 - COM	Digital Input 7	
	X8 - COM	Digital Input 8	
	X4 - COM	Digital Input 4	In addition to the characteristics of X1~X3、X5~X8, it can also be used as a high-speed pulse input channel. Maximum input Frequency: 100kHz Input Impedance: 1.03k Ω
Analog Output	AO1 - GND	Analog Output 1	The voltage or current output is determined by the choice of the J2 jumper on the control panel. Output voltage range: 0V~10V Output current range: 0mA~20mA
	AO2 -GND	Analog Output 2	The voltage or current output is selected by the J3 jumper on the control panel. Output voltage range: 0V~10V Output current range: 0mA~20mA
Digital Output	Y1 - +24V	Digital Output 1	Optical coupling isolation, Open collector output. Output voltage range: 0V~24V Output current range: 0mA~50mA
	DO1 - COM(Retain)	High speed pulse output	High speed pulse output up to 100kHz
Relay Output	TA1 - TB1	NC terminal	Contact driving capacity: 250Vac, 3A, COS ϕ =0.4, 30Vdc, 1A
	TA1 - TC1	NO terminal	
	TA2 - TB2	NC terminal	Contact driving capacity: 250Vac, 3A, COS ϕ =0.4, 30Vdc, 1A
	TA2 - TC2	NO terminal	
Communication Interface selection	485+	RS485 Communication positive end	Differential signal input and output, half duplex.
	485-	RS485 Communication negative end	
Auxiliary Interface	J11	External keypad interface	External Keypad
wire jumper	J1	AI1 Input selection	Voltage and current input is optional, default is voltage input
	J13	AI2 Input Selection	Voltage and current input is optional, default is current input
	J2	AO1 Output Selection	Voltage and current output is optional, default is voltage output
	J3	AO2 Output Selection	Voltage and current output is optional, default is current output

4.2.5 Signal input terminal wiring instruction:

1) AI Analog Input Terminal:

Weak analog voltage signals are particularly susceptible to external interference, so generally need to use shielded cable, and wiring distance as short as possible, do not exceed 20m, as shown in figure 4-5.

In some cases where the analog signal is seriously disturbed, a filter capacitor or ferrite core should be added to the source side of the analog signal, as shown in figure 4-6.

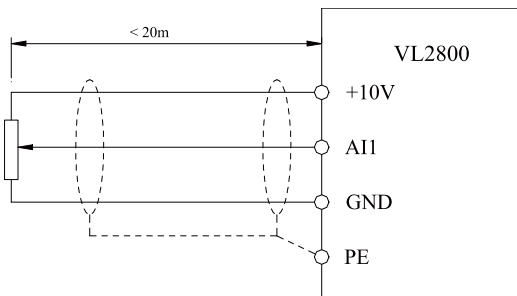

Picture 4-5 Analog input terminal wiring diagram

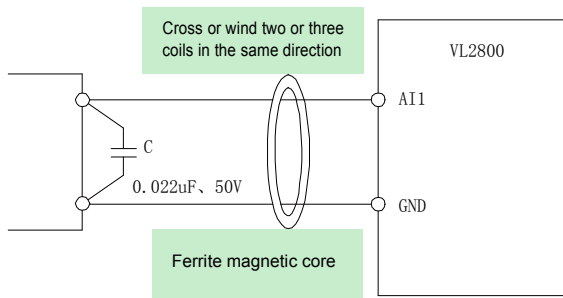

Picture 4-6 Analog input terminal processing wiring diagram

2) X Digital input terminal:

Generally need to use shielded cable, and wiring distance as short as possible, do not exceed 20m. When the active driving mode is selected, the necessary filtering measures should be taken for crosstalk of power supply. Contact control mode is recommended.

◆ SINK wiring

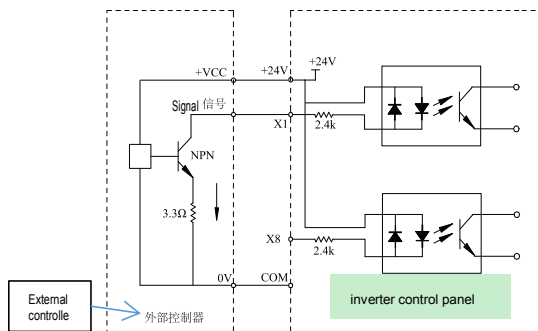

Picture 4-7 SINK wiring

This is the most common type of connection.

Note: In this connection mode, the x terminal of different ozone power supply can not be connected to use, otherwise it may cause x Maloperation; If need x terminal to connect (between different ozone power source), then need to connect diode in series at x terminal (anode to x) to use, diodes are required: $IF > 10\text{mA}$, $UF < 1\text{V}$, as shown below.

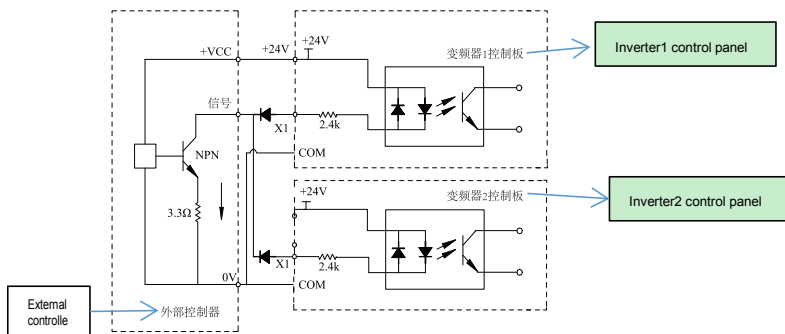

Picture 4-8 Multiple ozone power supply x terminals connected in parallel in SINK mode.

3) Y1 Digital Output Terminal:

When a digital output terminal is required to drive the relay, an absorption diode should be installed on either side of the relay coil. Otherwise, it is easy to damage the DC 24V power supply. The driving capacity is less than 50mA.

Note 1: Be Sure to properly install the polarity of the absorption diode. Here's how. Otherwise, when the digital output terminal has the output, will immediately burn out the DC 24V power supply.

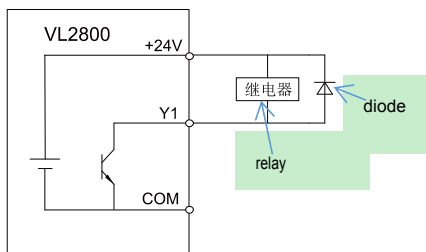

Picture 4-9 Digital output terminal wiring diagram

05、Basic Operation

5.1 Operation Panel Instructions

Ozone power supply can be operated, monitored and controlled by LED operation panel. In addition to the LED operation panel of ozone power supply, users can also choose the external operation panel.

Among them, the parameters can be modified and viewed through the LED operation panel, and the parameters can be copied, downloaded and other functions through the selection of the external operation panel.

5.2 LED operation panel

(the following is VL2800 series operation panel, and the operation mode of VL1800 is similar)

Through the operation panel, the ozone power supply can be set/modified/monitored/controlled (start, stop) and other operations. The appearance of the operation panel and the name of the operation key are shown in the following figure:

Command source indicator

OFF: Panel Run Command Channel;
ON: Terminal Run Command Channel;
blinking quickly: Communication run command channel;
blinking slowly: Analog runs command channel;

RUN indicator

OFF: Stop;
ON: operating;
blinking slowly: Zero-frequency operation;
blinking quickly: Dc brake;

Potentiometer

Shift key

RUN key

Forward/Reverserotation indicator

ON: reverse rotation
OFF: forward rotation

Tuning/Torque control indicator

ON: Torque control mode;
blinking slowly: Tuning status;

Data display area

Unit indicator

Multi-function key

Exit/shortcut key

Increment key

Enter/set key

Stop/Reset key

Decrement key

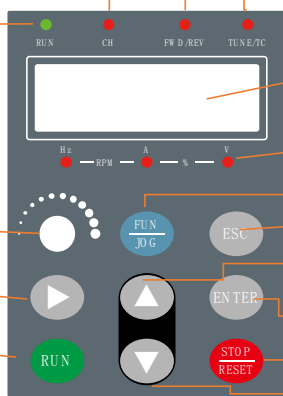

Picture 5-1 Operation panel diagram

5.2.1 Light Indicator:

Form 5-1 Indicator light description

Function indicator light			
Indicator Light			State specification
Name	Status		
RUN (RUN indicator)	OFF		Stop
	ON		operation
	blinking slowly		Zero-frequency operation
	blinking quickly		Dc brake
CH (Command source indicator)	OFF		Panel Run Command Channel
	ON		Terminal Run Command Channel
	blinking quickly		Communication run command channel
	blinking slowly		Analog runs command channel
FWD/REV (rotation indicator)	OFF		forward rotation
	ON		reverse rotation
TUNE/TC (Tuning Status / torque control indicator)	ON		Torque control mode
	blinking slowly		Tuning status
Unit indicator			
Hz frequency indicator	A Current indicator	V voltage indicator	State specification
ON	OFF	OFF	unit of frequency
OFF	ON	OFF	unit of current
OFF	OFF	ON	unit of voltage
ON	ON	OFF	unit of rotational speed
OFF	ON	ON	Percentage Unit
All the indicator lights are blinking slowly except the running indicator			Failure or alarm

5.2.2 LED Display area









There are 5-bit LED display on the operation panel, which can display setting frequency, output frequency, various monitoring data and alarm code, etc. .

Form 5-2 Actual correspondence table and LED display correspondence table.

ACTUAL SYMBOL	LED display	ACTUAL SYMBOL	LED display	ACTUAL SYMBOL	LED display
0	0	A	A	o	o
1	1	b	b	n	n
2	2	C	C	u	u
3	3	d	d	r	r
4	4	E	E	T	f
5	5	F	F	N	n
6	6	G	G	U	U
7	7	-	-	P	P
8	8	-	-	Y	Y
9	9	-	-	-	-

5.2.3 Keyboard Button Function

Form 5-3 A menu of keyboard keys

button	Name	Function
	Shift key	Press the shift key on the main interface to switch the display monitoring parameters (F38.10 ~ F38.15 can set the monitoring parameters); Press the shift key on the non-main interface, and the effective bits can be switched between ones, tens, hundreds, thousands and tens thousands.
	Multi-function key	Multi-function key (F37.00 can set its function) ; In the "Operation Panel" Start and stop control mode, for the point movement operation.
	Exit / Shortcut Key	Escape key Main interface to enter monitoring parameters and fault record parameters group (F39 group) shortcut key;
	Enter/set key	Step into the menu screen, set parameter confirmation.
	RUN key	In Operation Panel Start Stop Control Mode, used to run operations.
	Stop/Reset key	When running, press this key to stop running operation, this characteristic is restricted by function code F37.00; Can Be used for reset operation when the fault alarm state.
	Increment key	Increment of data or function code.
	Decrement key	Decrement of data or function code.

5.3Basic operation (Set parameters, restore factory values, command channel switch, change monitoring parameters, password lock and unlock)

5.3.1 Set parameters

Set parameters (the example restores the parameters to factory settings, other parameter settings are similar to this example) :

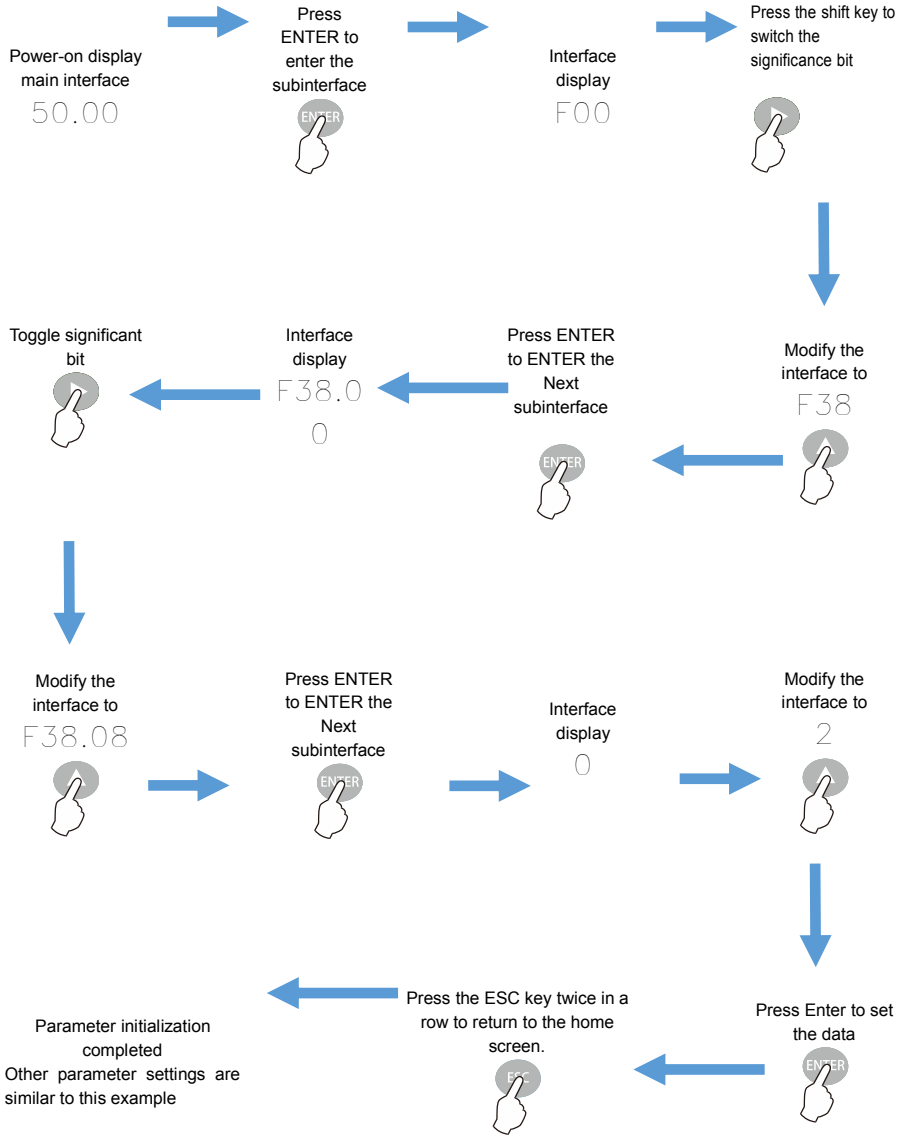

VL1800, VL2800 series ozone power supply parameters list	
1.Parameter List Reading Instruction	
Symbols	instructions
Function Number	Parameter number, that is, the number shown on the LED panel.
(Communication Address)	Represents the register address used for MODBUS communication, where H represents the hexadecimal value and the number represents the specific address.
Name	Parameter Name
(H)	Represents a hexadecimal value that can only be modified (not carried) by bits and is subject to upper and lower limits. (myriabit. housands, hundreds, tens, ones)
Range	Parameters set range, different control mode parameters set range may be different for different models.
factory default	Factory set value, different control mode different model factory set value may be different.
unit	V: (Voltage) Volt; A: (current) Ampere; C: (temperature) Centigrade; Ω: (Resistance) ohm; mH: (Inductance) Milligram; rpm: (speed) rpm;% : percent; BPS: (Baud Rate) Bit per second; Hz, Khz: (frequency) Hertz, Khz; ms, Sec. , Min. H: (time) ms, s, Min, H; KW: (Power) KW; 1: No units and so on
Change properties	Indicates whether the parameters can be changed and the conditions changed.
√	A parameter that can be modified in any state.
×	Non-modifiable parameters in the running state.
☆	Actual detection parameters cannot be modified.
★	Factory parameters are only modified by the factory. USERS ARE FORBIDDEN TO MODIFY THEM.
Content	A description of the parameter details
Function indicator description	<p>RUN indicator OFF: Stop;/ON: operating; /blinking slowly: Zero-frequency operation; /blinking quickly: Dc brake;</p> <p>Command source indicator OFF: Panel Run Command Channel; /ON: Terminal Run Command Channel; blinking quickly: Communication run command channel; blinking slowly: Analog runs command channel;</p> <p>FWD/REV (direction indicator) : ON: reverse rotation /OFF: forward rotation</p> <p>TUNE/TC (Tuning/Torque control indicator) : ON: Torque control mode; /blinking slowly: Tuning status; All the indicator lights are blinking slowly except the running indicator: Failure or alarm.</p>
Unit indicator description	<p>HZ: Frequency Unit; A: Current Unit; V: Voltage Unit; RMP (Hz + a) : Speed Unit;% (a + V) : percentage. Note: The Unit Indicator Light Hz is always on when the main interface shows the output frequency, and the unit indicator light Hz flashes slowly when the main interface shows the set frequency</p>
Key Definition	<p>► : Shift key; Press the shift key on the main interface to switch the display monitoring parameters (F38.10 ~ F38.15 can set the monitoring parameters); Press the shift key on the non-main interface, and the effective bits can be switched between ones, tens, hundreds, thousands and tens thousands. FUN/JOG: Multi-function key Multi-function key (F37.00 can set its function) ; ESC: Exit key / main interface entry, monitoring parameters and fault record, parameter group (F39 group) shortcut key; ENTER: Enter/set key; RUN: RUN key STOP/RESET: STOP/RESET(F37.00 can set its functions); ▲: Increment key; ▼: Decrement key; Long Press, increment key or decrement key in the main interface to quickly modify the relevant parameters (F01.08 can set its modified parameters) .</p>

2List of parameters		
GroupF00 - basic functional parameters		
Function Number (Communication Address)	Name	SCOPE [factory value] [changes properties] and contents
F00.00 (0000H)	Rated power of ozone power supply	(0.4 ~ 999.9)[model setting (KW)] [★] [☆] Note: CAN NOT BE INITIALIZED
F00.01 (0001H)	Run command channel selection	0~2 【0】 [√] 0: Panel Run Command Channel (Command source indicator is OFF) 1: Terminal Run Command Channel (Command source indicator is ON) 2: Communication run command channel (Command source indicator is blinking quickly)
F00.02 (0002H)	Stop Mode	0~1 【0】 [×] 0: Deceleration Stop 1: Free stop
F00.03 (0003H)	Power cut restart setting	0~1 【0】 [×] 0: invalid 1: effective When the power is switched on after power failure, if the starting conditions are met, the ozone power supply will automatically run in accordance with the set mode after waiting for the time defined by F03.09. Starting conditions: the starting time after power failure is set to 1 or 2. Before power failure, it is in the running state and there is no stop command. There is no stop command during the waiting time after power failure.
F00.04 (0004H)	Wait time for power failure to restart	0.0~100.0 【5.0Sec.】 [√]
F01-Frequency function parameters		
Function Number (Communication Address)	Name	SCOPE [factory value] [changes properties] and contents
F01.00 (0100H)	Frequency source selection	0~7 【1】 [√] 0: frequency panel potentiometer given (only valid for panel with potentiometer) 1: Digital frequency given1 2: Digital frequency given2 (Retention) 3: Frequency communication given1 (Absolute Value) (Retention) 4: Frequency communication given2 (Percentage) (Retention) 5: Frequency AI 1Analog given (0~10V/20mA) 6: Frequency AI 2Analog given (0~20mA) 7: Frequency pulse given (0~100KHZ) (Retention)
F01.01 (0101H)	Frequency source digital setting	200~ [F01.04] 【1000Hz】 [√]
F01.02 (0102H)	panel▲/▼Keys. Encoder adjustment control (H)	[F01.02] Pane▲/▼Keys. Encoder adjustment control (H) : 0000~011B 【0111】 [√] [F01.03] TerminalUP/DOWNadjustment control (H) : 0000~011B 【0111】 [√]
F01.03 (0103H)	Terminal UP/DOWNadjusting control (H)	LEDBit: Adjust valid channel selection 0: frequency panel potentiometer given (only valid for panel with potentiometer) 1: Digital frequency given1 2: Digital frequency given2 (Retention) 3: Frequency communication given1 (Absolute Value) (Retention) 4: Frequency communication given2 (Percentage) (Retention) 5: Frequency AI 1Analog given (0~10V/20mA) 6: Frequency AI 2Analog given (0~20mA) 7: Frequency pulse given (0~100KHZ) (Retention) 8: Torque digital setting (Retention)

		<p>9: PIDNumber set point A: Voltage Digital given (Retention) B: Proportional linkage coefficient LED ten's digit: Shut down. KEEP IT SET0: SHUTDOWN NOT MAINTAINED 1: Stop Hold LED Hundred's digit: Power off storage Settings 0: Power off and no storage 1: Power down storage LED Thousand bit: Retention When the effective channel selection of LED bit adjustment changes, the panel▲/▼key、encoder or terminal UP/DOWNThe modified value is reset to zero. Downtime is defined as the presence of a running status panel▲/▼key、encoder or terminal UP/DOWNThe modified value remains valid after the outage. While the stop is not maintained,After the machine is stopped, the modification made in this running state will be lost. Power-down storage refers to the on-state Panel▲/▼key、encoder or terminalUP/DOWNThe modified value is automatically stored after power off. The next power-up will still be on. If the power is lost without storage, it will lose the modification made after the power is cut off.</p>
F01.04 (0104H)	Maximum output frequency	<p>200~8000 【8000Hz】 【×】 0.4KW ~ 2.2KW 200~10000 【10000Hz】 【×】 3.0KW ~ 5.5KW 200~ 8000 【 6000Hz】 【×】 7.5KW ~ 18.5KW 200~ 8000 【 4000Hz】 【×】 22.0KW ~ 55.0KW 200~ 8000 【 3000Hz】 【×】 75.0KW ~ 250.0KW 200~ 4000 【 2000Hz】 【×】 280.0KW ~1100.0KW 200~ 2000 【 1000Hz】 【×】 The maximum output frequency is the maximum allowed output frequency of the ozone power supply, is the basis for calculating the acceleration and deceleration time.</p>
F01.05 (0105H)	Frequency rise time	0.10~600.00 【10.00 (Sec.)】 【√】
F01.06 (0106H)	Frequency drop time	Set the output frequency from 0 to the maximum frequency rise time, or set the output frequency from the maximum frequency to 0 down time.
Group F02 ~ group F12 - retention parameter group		
Function Number (Communication Address)	Name	SCOPE [factory value] [changes properties] and contents
F13 group - ozone power supply special parameters		
Function Number (Communication Address)	Name	SCOPE [factory value] [changes properties] and contents
F13.00 (0D00H)	Voltage-given Channel	<p>0~3 【1】 【√】 0: Panel potentiometer given (100% corresponding 【F13.02】) 1: Voltage Digital given 2: AI1 (100% corresponding 【F13.02】) 3: AI2 (100% corresponding 【F13.02】)</p>
F13.01 (0D01H)	Digital Voltage Setting	<p>0.0~ 【F13.02】 【0.0V】 【√】 Set the output voltage of ozone power supply.</p>
F13.02 (0D02H)	Voltage Limit Level	<p>0.0~Ue 【Ue×50%】 【√】 This parameter sets the maximum output voltage of ozone power supply</p>
F13.03 (0D03H)	Voltage rise time	0.10~600.00 【10.00Sec.】 【√】
F13.04 (0D04H)	Voltage drop time	0.10~600.00 【10.00Sec.】 【√】
F13.05 (0D05H)	Retention	50.0~200.0 【100.0%】 【√】

F13.06 (0D06H)	Working mode	0~1 【0】【√】 0: Constant voltage output 1: Constant current output
F13.07 (0D07H)	Current given channel	0~3 【1】【√】 0: Panel potentiometer given (100% corresponding to the rated current of Ozone Power Supply) 1: Current digital given (100% corresponding to the rated current of Ozone Power Supply) 2: AI1 (100% corresponding to the rated current of Ozone Power Supply) 3: AI2 (100% corresponding to the rated current of Ozone Power Supply)
F13.08 (0D08H)	Digital current setting	0.0~100.0% 【0.0%】【√】
F13.09 (0D09H)	Current adjustment deviation	0.0~30.0% 【5.0%】【√】 The current adjustment deviation is the percentage of the given value of the relative current
F13.10 (0D0AH)	Current detection selection	0~1 【0】【√】 0: invalid 1: effective
F13.11 (0D0BH)	Current detection level	0.0~100.0% 【90.0%】【√】
F13.12 (0D0CH)	Current detection delay time	0.0~60.0 【5.0Sec.】【√】
F13.13 (0D0DH)	Retention parameter	0~1 【0】【√】 0: invalid 1: effective

F14 - analog and pulse input parameters

Function Number (Communication Address)	Name	SCOPE [factory value] [changes properties] and contents
F14.00 (0E00H)	AI1 minimum input voltage (current)	0.00~10.00 【0.10V】【√】 Set The minimum input voltage of Terminal AI1. When current signal is selected, 0.00 v means 0.00 mA, 10.00 v means 20.00mA.
F14.01 (0E01H)	AI1 minimum input corresponding setting	0.0~100.0 【0.0%】【√】 The percentage of the actual physical quantities corresponding to the minimum input voltage of Terminal AI1.Above the corresponding set out of its scope to take its critical value.
F14.02 (0E02H)	AI1 maximum input voltage (current)	0.00~10.00 【10.00V】【√】 Set the maximum input voltage of terminal AI1. When the current signal is selected, 0.00V represents 0.00mA, and 10.00V represents 20.00mA.
F14.03 (0E03H)	AI1 maximum input corresponding setting	0.0~100.0 【100.0%】【√】 The percentage of the actual physical quantities corresponding to the maximum input voltage of Terminal AI1. Above the corresponding set out of its scope to take its critical value.
F14.04 (0E04H)	AI1 input filtering time	0.00~10.00 【0.10Sec.】【√】
F14.05 (0E05H)	AI2 minimum input voltage (current)	0.00~10.00 【0.10V】【√】 Set the minimum input voltage of terminal AI2. When the current signal is selected, 0.00V represents 0.00mA, and 10.00V represents 20.00mA.
F14.06 (0E06H)	AI2 minimum input corresponding setting	0.0~100.0 【0.0%】【√】 Set the percentage of the actual physical quantity when terminal AI2 inputs the minimum input voltage.When the above corresponding setting exceeds its range, its critical value is taken.
F14.07 (0E07H)	AI2 maximum input voltage (current)	0.00~10.00 【10.00V】【√】 Set the maximum input voltage of terminal AI2. When the current signal is selected, 0.00V represents 0.00mA, and 10.00V represents 20.00mA.
F14.08 (0E08H)	AI2 maximum input corresponding setting	0.0~100.0 【100.0%】【√】 Set the percentage of the actual physical quantity when terminal AI2 inputs the maximum input voltage.When the above corresponding setting exceeds its range, its critical value is taken.

F14.09 (0E09H)	AI2 input filtering time	0.00~10.00 【0.10Sec.】 <input checked="" type="checkbox"/>
F15 group - analog and pulse output parameters		
Function Number (Communication Address)	Name	SCOPE [factory value] [changes properties] and contents
F15.00 (0F00H)	AO1 output selection	0~99 【0】 <input checked="" type="checkbox"/> For more options, see: 《Table 1:Monitor parameter variable comparison table》
F15.01 (0F01H)	AO2 output selection	0~99 【0】 <input checked="" type="checkbox"/> For more options, see: 《Table 1:Monitor parameter variable comparison table》
F15.02 (0F02H)	AO1 minimum output	0.00~10.00 【0.00V】 <input checked="" type="checkbox"/> AO1Minimum output voltage of the terminal
F15.03 (0F03H)	AO1 minimum output corresponding quantity	0.0~100.0 【0.0%】 <input checked="" type="checkbox"/> The percentage of the physical quantity corresponding to the minimum output of the AO1 terminal, 100.0% of the corresponding physical quantity:For more options, see: 《Table 1:Monitor parameter variable comparison table》
F15.04 (0F04H)	AO1 maximum output	0.00~10.00 【10.00V】 <input checked="" type="checkbox"/> Maximum output voltage of AO1 terminal
F15.05 (0F05H)	AO1 maximum output corresponding quantity	0.0~100.0 【100.0%】 <input checked="" type="checkbox"/> The percentage of the physical quantity corresponding to the maximum output of the AO1 terminal, 100.0% of the corresponding physical quantity:For more options, see: 《Table 1:Monitor parameter variable comparison table》
F15.06 (0F06H)	AO1 output filtering time	0.00~10.00 【0.10Sec.】 <input checked="" type="checkbox"/>
F15.07 (0F07H)	AO2 minimum output	0.00~10.00 【0.00V】 <input checked="" type="checkbox"/> Minimum output voltage of AO2 terminal
F15.08 (0F08H)	AO2 Minimum output correspon den ce	0.0~100.0 【0.0%】 <input checked="" type="checkbox"/> The percentage of the physical quantity corresponding to the minimum output of the AO2 terminal,100.0% of the corresponding physical quantity:For more options, see: 《Table 1:Monitor parameter variable comparison table》
F15.09 (0F09H)	AO2 maximum output	0.00~10.00 【10.00V】 <input checked="" type="checkbox"/> Maximum output voltage value of AO2 TERMINAL
F15.10 (0F0AH)	AO2 Maximum output correspon den ce	0.0~100.0 【100.0%】 <input checked="" type="checkbox"/> The percentage of the physical quantity corresponding to the maximum output of the AO1 terminal, 100.0% of the corresponding physical quantity:For more options, see: 《Table 1:Monitor parameter variable comparison table》
F15.11 (0F0BH)	AO2Output filtering time	0.00~10.00 【0.10Sec.】 <input checked="" type="checkbox"/>

Schedule 1: comparison table of monitor parameter variables**Note: monitor variables do not take direction into account**

Serial Number	Monitor parameter variables	100.0%Full scale value
0	No output	-
1	Output frequency (before slip compensation)	Maximum frequency
2	Output frequency (after slip compensation)	Maximum frequency
3	Motor (Retention) speed	Maximum frequency*60/Motor(Retention)Polar Logarithm
4	output current	250%*Ozone power supply rated current
5	output torque (Retention)	Digital setting of corresponding upper torque limit

06、List of parameters

6	Output Voltage	Motor(Retention)nominal voltage
7	Output Power	3*Motor(Retention) rated power
8	Equipment Temperature Temperature 1 and temperature 2 Take a higher value	100.0℃
9	Bus Voltage	220V type: 500V 380V type: 1000V
10	Set frequency	Maximum frequency
11	Speed Instruction (Retention)	Maximum frequency*60/Motor(Retention)Polar Logarithm
12	Torque Instruction (Retention)	300% rated torque
13	Target Frequency	Maximum frequency
14	Speed regulator deviation (Retention)	Maximum frequency*60/Motor(Retention)Polar Logarithm
15	Speed governor output (Retention)	300.0%
16	Process PID set	100.0%
17	Process PID Feedback	100.0%
18	Process PID Absolute deviation (Retention)	100.0%
19	Process PID Output	100.0%
20	AI1 input	10.00V (20.00mA)
21	AI2 input	10.00V (20.00mA)
22	Communication given analog quantity	100.0%
23	Communications GIVEN PULSE	100.0%
24	External pulse input frequency	Maximum input frequency of external pulse
25	Current linear velocity (Fin calculation)	Maximum permissible linear velocity
26	Accumulated length (linear velocity)	Maximum comptroller
27	Counter value	Counter period value
28	Timer value	Timer period value
29~99	Retention	-

Group F16 - switching input parameters

Function Number (Communication Address)	Name	SCOPE [factory value] [changes properties] and contents
F16.00 (1000H)	Input terminal X1 function	0~99 【0】 <input checked="" type="checkbox"/> See detailed functional options: 《Table 2:Multi-function input terminal comparison table》
F16.01 (1001H)	Input terminalX2 function	0~99 【0】 <input checked="" type="checkbox"/> See detailed functional options: 《Table 2:Multi-function input terminal comparison table》
F16.02 (1002H)	Input terminalX3 function	0~99 【0】 <input checked="" type="checkbox"/> See detailed functional options: 《Table 2:Multi-function input terminal comparison table》
F16.03 (1003H)	Input terminalX4 function	0~99 【0】 <input checked="" type="checkbox"/> See detailed functional options: 《Table 2:Multi-function input terminal comparison table》
F16.04 (1004H)	Input terminalX5 function	0~99 【0】 <input checked="" type="checkbox"/> See detailed functional options: 《Table 2:Multi-function input terminal comparison table》
F16.05 (1005H)	Input terminalX6 function	0~99 【0】 <input checked="" type="checkbox"/> See detailed functional options: 《Table 2:Multi-function input terminal comparison table》
F16.06 (1006H)	Input terminalX7 function (X7-FWD)	0~99 【1】 <input checked="" type="checkbox"/> See detailed functional options: 《Table 2:Multi-function input terminal comparison table》
F16.07 (1007H)	Input terminalX8 function (X8-REV)	0~99 【0】 <input checked="" type="checkbox"/> See detailed functional options: 《Table 2:Multi-function input terminal comparison table》

F16.08 (1008H)	Input terminal Effective status setting 1 (H)	0000~1111 【0000】【√】 LED unit's digit: X1 Logical Setting LED ten's digit: X2 Logical Setting LED Hundred's digit: X3 Logical Setting LED Thousand's digit: X4 Logical Setting 0: represents the positive logic, that is, the corresponding terminal and the public connection is valid, disconnect is invalid 1: Represents the anti-logic, that is, the corresponding terminal and the public connection invalid, disconnect valid
F16.09 (1009H)	Input terminal Effective status setting2 (H)	0000~1111 【0000】【√】 LED unit's digit: X5 Logical Setting LED ten's digit: X6 Logical Setting LED Hundred's digit: X7 Logical Setting LED Thousand's digit: X8 Logical Setting 0: represents the positive logic, that is, the corresponding terminal and the public connection is valid, disconnect is invalid 1: Represents the anti-logic, that is, the corresponding terminal and the public connection invalid, disconnect valid
F16.10 (100AH)	Input terminal filtering time	0~200 【20ms】【√】
F16.11 (100BH)	Terminal control mode (FWD、REV、SlN)	0~3 【0】【√】 0: Two-wire control mode1 1: Two-wire control mode2 2: Three-wire control mode1 3: Three-wire control mode2
F16.12 (100CH)	Power on terminal running protection selection	0~1 【0】【√】 0: The terminal running command is invalid when power on(the terminal is first disconnected and then closed) 1: The terminal running command is valid when the power is on. The given signal of the two-wire mode operation instruction is the level signal. When the terminal is in the effective state, the ozone power supply will start automatically.In a system that does not want to be powered up by itself, the terminal operation command can be selected to be invalid when powered up.
F16.13 (100DH)	UP/DOWN Terminal frequency modification rate	10~1000 【100Hz/S】【√】

Attached table 2: multi-function input terminal function comparison table

Serial Number	function	Serial Number	function
0	Control end idle	1	Running forward (FWD)
2	Reverse run (REV)	3	Three-wire operation control (SlN)
4	Forward turning point control	5	Reverse point control
6	Free stop control	7	Fault reset signal
8	External device 1 fails	9	External device 2 fails
10	External equipment 3 failure	11	External equipment 4 failure
12	Emergency shutdown input	13	Increasing frequency (UP)
14	Decreasing frequency (DOWN)	15	UP/DOWN Terminal frequency reset
16	Auxiliary frequency reset	17	Frequency source A switches to B
18	Frequency source A switches to A+B	19	Switching frequency source A to a-b
20	Multispeed option 1	21	Multispeed option 2
22	Multispeed option 3	23	Multispeed option 4
24	Acceleration and deceleration time selection1	25	Acceleration and deceleration time selection2
26	No acceleration and deceleration	27	Overexcitation deceleration (flux braking)
28	Run command channel selection 1	29	Run command channel selection 2
30	Run the command to switch to the keyboard	31	Run the command to switch to the terminal
32	Run command to switch to communication	33	Prohibit Operating Instructions
34	PID Control input	35	PID Suspension control
36	PID Set the increment (Retention)	37	PID Set decrement (Retention)

06、List of parameters

38	Terminal PID setting reset (Retention)	39	PID Number Given Selection 1
40	PID Number Given Selection 2	41	Retention
42	Swing frequency control input	43	pendulum frequency control Suspension (Retention)
44	Swing Frequency Control Reset	45	PLC Control input
46	PLC Suspension control (Retention)	47	PLC Control reset
48	Counter trigger signal	49	Counter input signal
50	Counter reset signal	51	Counter reset signal
52	Timer trigger signal	53	Timer reset signal
54	The timer clears the signal	55	Pulse frequency input (valid for DI4 only)
56	Length count input (valid for DI4 only)	57	Cumulative length clearing
58	V-FThe separation voltage setting is increasing (Retention)	59	V-F The separation voltage setting decreases (Retention)
60	Terminal voltage reset (Retention)	61	Speed and torque control switching
62	Torque control prohibited	63	Torque number given selection1
64	Torque number given selection2	65	Retention
66	Torque upper limit selection1	67	Torque upper limit selection 2
68	Retention	69	Zero servo input
70	Droop control input	71	Water shortage fault input
72	Temperature overheating fault input	73~99	Retention

F17 group - switch quantity output parameter

Function Number (Communication Address)	Name	SCOPE [factory value] [changes properties] and contents
F17.00 (1100H)	Open collector Output terminal Y1 function	0~99 0 <input type="checkbox"/> <input checked="" type="checkbox"/> See detailed functional options: 《Table 3:Multi-function output terminal comparison table》
F17.01 (1101H)	Open collector Output terminal Y2 function (keep)	0~99 0 <input type="checkbox"/> <input checked="" type="checkbox"/> See detailed functional options: 《Table 3:Multi-function output terminal comparison table》
F17.02 (1102H)	Programmable relay R1 function	0~99 4 <input type="checkbox"/> <input checked="" type="checkbox"/> See detailed functional options: 《Table 3:Multi-function output terminal comparison table》
F17.03 (1103H)	Programmable relay R2 function	0~99 0 <input type="checkbox"/> <input checked="" type="checkbox"/> See detailed functional options: 《Table 3:Multi-function output terminal comparison table》
F17.04 (1104H)	The output terminals Effective state setting (H)	0000~1111 0000 <input type="checkbox"/> <input checked="" type="checkbox"/> LED unit's digit : Y1Logical Setting LED ten's digit : Y2Logical Setting LED Hundred's digit : R1Logical Setting LED Thousand's digit : R2Logical Setting 0: Represents Positive Logic, that is, the output terminal is effectively connected to the common terminal, the disconnection is invalid. 1: Represents the anti-logic, that is, the output terminal is not connected to the common terminal, the disconnection is valid.
F17.05 (1105H)	Y1 output delay time	0.0~100.0 0.0Sec. <input type="checkbox"/> <input checked="" type="checkbox"/> This function code defines a delay between a change in the state of the Y 1 output and a change in the y 1 output.
F17.06 (1106H)	Y2 output delay time	0.0~100.0 0.0Sec. <input type="checkbox"/> <input checked="" type="checkbox"/> This function code defines a delay between a change in the state of the Y 2 output and a change in the y 2 output.
F17.07 (1107H)	R1 output delay time	0.0~100.0 0.0Sec. <input type="checkbox"/> <input checked="" type="checkbox"/> This function code defines the delay between a change in the R1 state of the relay and a change in the output of the relay.
F17.08 (1108H)	R2 output delay time	0.0~100.0 0.0Sec. <input type="checkbox"/> <input checked="" type="checkbox"/> This function code defines the delay between a change in the R2 state of the relay and a change in the output of the relay.

Attached table 3: multi-function output terminal comparison table			
Serial Number	function	Serial Number	function
0	no output	1	ready
2	Running forward	3	Reverse run
4	fault output	5	The alarm output
6	Fault or alarm output	7	Zero-frequency operation
8	The non-zero run	9	Accelerated operation
10	Decelerate Operation	11	Constant speed operation
12	Limit loss in quick action	13	In overpressure stall action
14	Undervoltage downtime	15	In the upper limit of swing frequency
16	In the lower limit of the pendulum frequency	17	Torque limitation (retention)
18	Overtorque detection (retention)	19	Undertorque detection (retention)
20	Energy consumption braking action	21	Dc braking action
22	Deceleration overexcitation action (flux braking)	23	Monitor 1 output
24	Monitor 2 output	25	Monitor 3 output
26	Monitor 4 output	27	The counter detection value reaches the output
28	The counter cycle value reaches the output	29	The timer detection value reaches the output
30	The timer cycle value reaches the output	31	Length to output
32	The operation of simple PLC in the current stage is completed (0.5s pulse)	33	Simple PLC current cycle operation completed (0.5s pulse)
34	Simple PLC complete cycle operation (0.5s pulse)	35	Complete all cycle operation of simple PLC (continuous level)
36	PID In sleep	37	Frequency arrival signal (FAR)
38	Processing frequency pump output	39	One tow two (motor (retained)1)
40	One tow two (motor (retained)2)	39~ 99	Retention

Group F18 ~ F23 - retention parameter group (Retention)		
Function Number (Communication Address)	Name	SCOPE [factory value] [changes properties] and contents
F24 group - protection function parameters		
Function Number (Communication Address)	Name	SCOPE [factory value] [changes properties] and contents
F24.00 (1800H)	Cooling fan control	0~1 【0】 [√] 0: automatic control 1: the electrification process has been running Automatic control means that the internal temperature detection program is automatically started during the operation of the ozone power supply, and the operation and stop of the fan are determined according to the module temperature status and the operation status of the ozone power supply.
F24.01 (1801H)	Frequency of automatic fault reset	0~100 【0】 [√] When set to 0, it means that the automatic fault reset function is off; when set to 100, it means that the automatic fault reset function has no frequency limit, that is, countless times. When the fault self-reset function is effective, if the ozone power supply is in the running state before the fault, the ozone power supply will start up with the speed tracking when the fault is reset.

F24.02 (1802H)	Fault automatic reset interval time	0.1~10.0 【1.0Sec.】 【√】 The shortest interval from the current fault self-reset to the next fault self-reset.
F25 group - advanced functional parameters (retained)		
Group F26 - communication function parameters		
Function Number (Communication Address)	Name	SCOPE [factory value] [changes properties] and contents
F26.00 (1A00H)	Communication configuration (H)	0000~1551 【0030】 【×】 LED units' digit: Protocol selection 0: MODBUS 1: Customizing (Retention) LED Ten' digit : Communication baud rate setting 0: 1200BPS 1: 2400BPS 2: 4800BPS 3: 9600BPS 4: 19200BPS 5: 38400BPS 6: 79600BPS (Retention) 7: 115200BPS (Retention) LED Hundred's digit: The data format 0: 1-bit initiation bit, 8-bit data bits, 1 bit stop bit, No check for RTU 1: 1-bit initiation bit, 8-bit data bits, 1 bit stop bit, Parity check for RTU 2: 1-bit initiation bit, 8-bit data bits, 1 bit stop bit, Odd parity check for RTU 3: 1-bit initiation bit, 8-bit data bits, 2 bit stop bit, No check for RTU 4: 1-bit initiation bit, 8-bit data bits, 2 bit stop bit, Parity check for RTU 5: 1-bit initiation bit, 8-bit data bits, 2 bit stop bit, Odd parity check for RTU LED Thousand's digit: 0: The write operation has a response 1: Write operation no response
F26.01 (1A01H)	Local machine address	0~247 【1】 【×】 0: master station 1~247: Slave station This parameter is used for serial port communication, set the address of this ozone power supply, 0 is the broadcast address. When set to the broadcast address, only the broadcast command can be sent without answering the host computer. 1 ~ 247 slave address, set as slave address, in the communication process, the machine only with the native address (or broadcast address) consistent data frame to receive instructions, and reply frame (broadcast address instruction does not respond).
F26.02 (1A02H)	Local reply (send) delay	0~1000 【5ms】 【×】 When the ozone power supply is the main engine, this is the transmission delay time, the minimum delay time is 30ms, if the set value is less than 30ms, it is 30ms. When the ozone power supply is the slave machine, this is the response delay time, and the actual response delay time is not less than the transmission time of 3.5 characters.
F26.03 (1A03H)	Communication abnormal action selection	0000~0022 【0010】 【×】 LED units' digit: Communication abnormal detection selection 0: No abnormal communication detected 1: Any state is checked 2: Run status detection only LED Ten' digit: Communication abnormal action selection 0: Communication failures (E-30) Free shutdown 1: Alarm (A-30) and maintain the status quo 2: Alarm (a-30) and stop the machine according to the set stop mode LED Hundred's digit: Retention LED Thousand's digit: Retention
F26.04 (1A04H)	Communication anomaly determination time	0.1~100.0Sec. 【10.0】 【√】 After the time delay is determined, the normal communication is still unable and the abnormal communication is handled.
Group F27 ~ Group F36-reserved parameter of Special Function		

Group F37 - panel related parameters		
Function Number (Communication Address)	Name	SCOPE [factory value] [changes properties] and contents
F37.00 (2500H)	Panel function key setting (H)	0x0000~0x0144 【0x0140】 【×】 LED units' digit : M-FUNC Key function selection 0: JOG(Positive inching turning) 1: JOG(reverse inching turning) 2: Reverse operation 3: Forward and Reverse Switching 4: Clear Panel▲/▼key Set frequency LEDTen' digit: STOP/RSTKey function selection 0: only valid for keyboard control 1: effective for both keyboard and terminal control 2: effective for both keyboard and communication control 3: effective for both keyboard and analog command control(Retention) 4: works for all control modes LED Hundred's digit : STOP+RUNKey function selection 0: invalid 1: Free Parking LED Thousand's digit: Retention
F37.01 (2501H)	Panel▲/▼、Encoder Adjustment Rate	10~1000 【100】 【√】
F37.02 (2502H)	Panel communication abnormal action	0~2 【1】 【√】 0: protect action and stop freely 1. Alarm and maintain the status quo 2. Alarm and stop according to the set stop mode
F37.03 (2503H)	Panel communication timeout checkout time	0.0~100.0 【1.0Sec.】 【√】 Note: do not do panel timeout detection when set to 0.0
Group F38-system management parameters		
Function Number (Communication Address)	Name	SCOPE [factory value] [changes properties] and contents
F38.00 (2600H)	User Password	0~65535 【0】 【√】 0: No Password Protection 1~65535: Password protected, Group F00 ~ F39 parameters need to verify the password to view and modify Password setting: ENTER this parameter without password, the interface displays "00000", set the password value (non-zero) and press "ENTER", the interface prompts "AgAln", set the password value AgAln and press "ENTER" to ENTER.If the setting values are the same, the interface prompts "End", then the password is set successfully, and the password protection will take effect immediately;If the Settings entered twice are different, the interface prompts "Error", then the password setting fails and needs to be reset. Password unlock: enter this parameter with password status, the interface displays "----", enter the password value set last time.If the password matches, the interface jumps to the next parameter, and the password is unlocked successfully;If the password does not match, the interface will prompt "Error", and the password unlock fails, and shall be unlocked again. Note: CAN NOT BE INITIALIZED
F38.01 (2601H)	Agent password	0~65535 【0】 【√】 0: No Password Protection 1 ~ 65535: F0.00 REQUIRES PASSWORD VERIFICATION TO BE MODIFIED. Password settings and password unlock operation the same user password (F38.00) , but the password unlock 10 minutes will be automatically locked. Note: CAN NOT BE INITIALIZED

06、List of parameters

F38.02 (2602H)	Run limit function password	0~65535 【0】 <input type="checkbox"/> <input checked="" type="checkbox"/> 0: No Password Protection 1 ~ 65535: F38.03, F38.04 need to verify password to view and modify. Password settings and password unlock operations with the same user Password (F38.00) Note: CAN NOT BE INITIALIZED
F38.03 (2603H)	Run limit function selection	0~1 【0】 <input type="checkbox"/> <input checked="" type="checkbox"/> 0: ban 1: restricted operation The operation time is calculated from the effective start of the limited operation. When the measured operation time is greater than the set operation limit time, the ozone power supply enters the operation limit time and reaches the protection, indicating e-21, which can be contacted with the direct supplier. Note: CAN NOT BE INITIALIZED
F38.04 (2604H)	Operating limit time	0.0~6000.0 【10.0h】 <input type="checkbox"/> <input checked="" type="checkbox"/> The operation time is calculated from the effective start of the limited operation. When the measured operation time is greater than the set operation limit time, the ozone power supply enters the operation limit time and reaches the protection, indicating e-21, which can be contacted with the direct supplier. Note: CAN NOT BE INITIALIZED
F38.05 (2605H)	LCD keyboard Display language selection	0~2 【0】 <input type="checkbox"/> <input checked="" type="checkbox"/> 0: Chinese 1: English 2: keep Note: CAN NOT BE INITIALIZED
F38.06 (2606H)	parameter Display mode selection (H)	0~3 【1】 <input type="checkbox"/> <input checked="" type="checkbox"/> LEDunits' digit: Parameter display mode selection (reserved) LEDTen' digi: Main interface monitoring parameter cycle display selection 0~1 【0】 <input type="checkbox"/> <input checked="" type="checkbox"/> 0: Do Not Cycle (the main interface only shows a monitoring parameters, need to show other parameters can be switched through the shift key) 1: AUTOMATIC LOOP (F38.10 ~ F38.12 or F38.13 ~ F38.15 set by the monitoring parameters loop display, each parameter display 5 seconds to switch to the next display parameters)
F38.07 (2607H)	Write protection	0~2 【0】 <input type="checkbox"/> <input checked="" type="checkbox"/> 0: All parameters are allowed to be modified (some parameters can not be modified at run time) 1: only allow to change the frequency setting F01.06, F01.07 2: All parameters ARE FORBIDDEN TO BE MODIFIED The above restrictions are not valid for this function code and User Password
F38.08 (2608H)	Parameter initialization	0~4 【0】 <input type="checkbox"/> <input checked="" type="checkbox"/> <input type="checkbox"/> <input type="checkbox"/> 0: No Operation 1: User Parameter Initialization 1 2: User Parameter Initialization 2 3: User Parameter Initialization 3(reserved) 4: clear the fault record (the contents of the fault record are reset to F39.76 ~ F39.99)

F38.09 (2609H)	Parameter copy function	<p>0~3 【0】 <input type="checkbox"/> ×</p> <p>0: no operation 1: parameters are uploaded to the panel 2: all function code parameters are downloaded to the ozone power supply 3: all function code parameters except the motor (reserved) parameters are downloaded to the ozone power supply</p> <p>When set to 1 and confirmed, the ozone power will upload all the function code set values between F00.00 and F38.15 in the control panel to the memory of the operation panel for storage. After setting it to 2 and confirming, ozone power will download all the function code set values between F00.00 and F38.15 in the operation panel to the internal control board for storage. After setting it to 3 and confirming, ozone power will download all the function code set values between F00.00 and F38.15 in the operation panel to the internal control board for storage.(motor parameters of F04 group and F05 group are not downloadable)</p> <p>Note: 1) for the operation panel, the parameters must be uploaded first, otherwise the memory of the operation panel is empty;After a parameter upload operation, the function code parameters will always be saved in the memory of the operation panel. 2) before the operation of the download as a parameter to ozone power supply, power of ozone will check the integrity of the function code within the operation panel parameters and version information, if the memory is empty, or parameter is not complete, or parameter version does not accord with the current ozone power supply software version (different) function code number, all can not download the parameters, and prompt copy error information; 3) after parameter download, the parameters in the memory of the operation panel still exist, so repeated copies of multiple ozone power sources can be performed.</p>
F38.10 (260AH)	Operation status monitoring parameter 1	<p>0~99 【9】 <input type="checkbox"/> √</p> <p>This parameter defines one of the monitoring parameters that can be displayed on the main interface under the running state of ozone power supply. For example, the default setting is 4, which means that monitoring parameters and fault record group (F39 group) no. 4 parameter F39.04 "output frequency" can be displayed. The next monitoring parameter can be displayed through the shift key on the main interface. Detailed functional options can be found in <F39 Group - Monitoring Parameters and Fault Records></p>
F38.11 (260BH)	Operation status monitoring parameter 2	<p>0~99 【4】 <input type="checkbox"/> √</p> <p>This parameter defines one of the monitoring parameters that can be displayed on the main interface under the running state of ozone power supply. For example, the default setting is 9, which means that monitoring parameters and fault record group (F39 group) no.9 parameter F39.9 "output voltage" can be displayed. The next monitoring parameter can be displayed under the main interface by the shift key. Detailed functional options can be found in <F39 Group - Monitoring Parameters and Fault Records></p>
F38.12 (260CH)	Operation status monitoring parameter 3	<p>0~99 【10】 <input type="checkbox"/> √</p> <p>This parameter defines one of the monitoring parameters that can be displayed on the main interface under the running state of ozone power supply. For example, the default setting is 10, which means that the monitoring parameters and fault record group (F39 group) no.10 parameter F39.10 "output current" can be displayed. The next monitoring parameter can be displayed under the main interface through the shift key. Detailed functional options can be found in <F39 Group - Monitoring Parameters and Fault Records></p>
F38.13 (260DH)	Downtime monitoring parameter 1	<p>0~99 【37】 <input type="checkbox"/> √</p> <p>This parameter defines one of the monitoring parameters that can be displayed on the main interface under the shutdown state of ozone power supply. For example, the default setting is 3, which means that monitoring parameters and fault record group (F39 group) no. 3 parameter F39.03 "target frequency" can be displayed. The next monitoring parameter can be displayed under the main interface through the shift key. Detailed functional options can be found in <F39 Group - Monitoring Parameters and Fault Records></p>

06. List of parameters

F38.14 (260EH)	Downtime monitoring parameter 2	0~99 【2】【√】 This parameter defines one of the monitoring parameters that can be displayed on the main interface under the shutdown state of ozone power supply. For example, the default setting is 16, which means the monitoring parameters and fault record group (F39 group) no.16 parameter F39.16 "input voltage" can be displayed. The next monitoring parameter can be displayed under the main interface by the shift key. Detailed functional options can be found in <F39 Group - Monitoring Parameters and Fault Records>
F38.15 (260FH)	Downtime monitoring parameter 3	0~99 【17】【√】 This parameter defines one of the monitoring parameters that can be displayed on the main interface under the shutdown state of ozone power supply. For example, the default setting is 17, which means that monitoring parameters and fault record group (F39 group) no.17 parameter F39.17 is "bus voltage". The next monitoring parameter can be displayed under the main interface through the shift key. Detailed functional options can be found in <F39 Group - Monitoring Parameters and Fault Records>
F38.16 (2610H)	Panel software version number	1.00~99.99 【1.00】【☆】 Note: CAN NOT BE INITIALIZED
F38.17 (2611H)	Control software version number	1.00~99.99 【1.00】【☆】 Note: CAN NOT BE INITIALIZED
F38.18 (2612H)	Bus voltage correction	0.0~800.0 【0.0V】【★】【×】 This parameter is used for bus voltage correction. When the ozone power supply is stopped, directly input the correct bus voltage value, that is, the bus voltage correction is completed. After the correction is completed, this parameter will automatically reset to zero. Note: in the case of bus voltage correction, the correction will be abandoned if the difference between the input correction bus voltage value and the detected voltage value is greater than 50%. At this time, there may be a hardware fault. Please correct after removing the hardware fault. Note: CAN NOT BE INITIALIZED
Group F39-monitoring parameters and failure records		
Function Number (Communication Address)	Name	SCOPE [factory value] [changes properties] and contents
F39.00 (2700H)	Set frequencyA	0~8000 【0Hz】【☆】
F39.01 (2701H)	Set frequencyB(Retention)	0~8000 【0Hz】【☆】
F39.02 (2702H)	Set frequency (combined frequency)	0~8000 【0Hz】【☆】
F39.03 (2703H)	target frequency (frequency order)	0~8000 【0Hz】【☆】 Monitor the final frequency set by the user and the target frequency of operation of the ozone power supply.
F39.04 (2704H)	The output frequency (before slip compensation)	0~8000 【0Hz】【☆】 Monitor the output frequency of the Ozone Power Supply (excluding slip compensation).
F39.05 (2705H)	output frequency (Retention) (after slip compensation)	0~8000 【0Hz】【☆】 Monitor the output frequency of the Ozone Power Supply (including slip compensation) .
F39.06 (2706H)	Estimated frequency of Motor(Retention)	0~8000 【0Hz】【☆】 The operating frequency of the motor as estimated by the monitoring program.
F39.07 (2707H)	Measured frequency of motor(Retention)	0~8000 【0Hz】【☆】 Monitor the actual motor operating frequency measured by photoelectric encoder.
F39.08 (2708H)	Motor speed(Retention)	0~60000 【0rpm】【☆】 Monitor the running speed of motor.
F39.09 (2709H)	output voltage	0.0~1140.0 【0.0V】【☆】 Monitor the output voltage of ozone power supply.
F39.10 (270AH)	output current	0.0~6000.0 【0.0A】【☆】 Monitor the output current of ozone power supply.

F39.11 (270BH)	torque current(Retention)	-3000.0~3000.0 【0.0A】☆☆ Monitor the torque current when the motor is running.
F39.12 (270CH)	flux current (Retention)	-3000.0~3000.0 【0.0A】☆☆ Monitor the excitation current of the motor during operation.
F39.13 (270DH)	output torque (Retention)	-300.0~+300.0 【0.0%】☆☆ Monitor the percentage of the motor output torque relative to the rated Torque.
F39.14 (270EH)	output power (Retention)	-300.0~+300.0 【0.0%】☆☆ Monitor the percentage of the motor output power relative to the rated power.
F39.15 (270FH)	Motor power factor (Retention)	-1.00~1.00 【0.00】☆☆ Monitor the power factor when the motor is running.
F39.16 (2710H)	input voltage	0.0~1140.0 【0.0V】☆☆ Monitor input voltage of ozone power supply.
F39.17 (2711H)	Bus voltage	0.0~2500.0 【0.0V】☆☆ Monitor DC bus voltage of ozone power supply.
F39.18 (2712H)	analog input AI1	0.00~10.00 【0.00V】☆☆ Monitor the input voltage value of analog input 1. If the input is current, it will be converted to voltage value. Converted voltage value = input current 500 ohms
F39.19 (2713H)	analog input AI2	0.00~10.00 【0.00V】☆☆ Monitoring analog input 2 input voltage value, if the input current is converted to the voltage value. Converted voltage value = input current 500 ohms
F39.20 (2714H)	Pulse frequency input (Retention)	0.00~100.00 【0.00kHz】☆☆ Monitor external pulse input frequency.
F39.21 (2715H)	PID set value (Retention)	0.0~100.0 【0.0%】☆☆ Monitor the target value set by PID.
F39.22 (2716H)	PIDFeedback value (Retention)	0.0~100.0 【0.0%】☆☆ Monitor the actual PID feedback.
F39.23 (2717H)	Analog output AO1	0.00~10.00 【0.00V】☆☆ Monitoring analog output 1 output voltage value, if the output current is converted to the voltage value. Converted voltage value = output current 500 ohms.
F39.24 (2718H)	Analog output AO2	0.00~10.00 【0.00V】☆☆ The monitoring analog outputs a voltage value of 2, which is converted to a voltage value if the output is current. Converted voltage value = output current 500 ohms.
F39.25 (2719H)	Pulse frequency output(Retention)	0.00~100.00 【0.00kHz】☆☆ Monitor pulse frequency of DO3 output.
F39.26 (271AH)	Terminal input status (H)	0000~00FF 【0000】☆☆ illustration
F39.27 (271BH)	Terminal output status (H)	0000~00FF 【0000】☆☆ illustration
F39.28 (271CH)	Ozone power supply operation status1 (H)	0000~FFFF 【0000】☆☆ illustration
F39.29 (271DH)	Ozone power supply operation status2 (H)	0000~FFFF 【0000】☆☆ illustration
F39.30 (271EH)	Ozone power supply operation status3 (H)	0000~FFFF 【0000】☆☆ illustration
F39.31 (271FH)	Multi - segment speed (PLC) current segment number(Retention)	0~15 【0】☆☆
F39.32 (2720H)	Current count(Retention)	0~60000 【0】☆☆
F39.33 (2721H)	Current time value(Retention)	0~60000 【0Sec.】☆☆
F39.34 (2722H)	Current length value(Retention)	0~60000 【0m】☆☆

06、List of parameters

F39.35 (2723H)	Operating Line Speed(Retention)	0.01~500.00 【0.00m/Sec.】【☆】
F39.36 (2724H)	Running limits the remaining time	0.0~6000.0 【10.0h】【√】 When the operation restriction function is effective, the monitoring operation restriction remaining time is monitored; when the operation restriction function is invalid, the monitoring value is 6000.0.
F39.37 (2725H)	Set voltage	0.0~Ue 【0.0V】【☆】
F39.38 (2726H)	feedback voltage	0.0~Ue 【0.0V】【☆】
F39.39 (2727H)	Set the current The percentage	0.0~100.0 【0.0%】【☆】 Monitor the set current of ozone power supply in percentage.
F39.40 (2728H)	Set the current ampere	0.0~6000.0 【0.0A】【☆】 Monitor the setting current of the ozone power supply in Amperes.
F39.41 ~F39.68	Retention	Monitoring parameters of special model(Retention)
F39.69 (2745H)	Module Temperature	0.0~125.0 【0.0℃】【☆】 Monitor the real-time temperature of IGBT module.
F39.70 (2746H)	Radiator temperature	0.0~125.0 【0.0℃】【☆】 Monitor the radiator temperature in real time.
F39.71 (2747H)	Accumulative power on time of the machine	0~65535 【0H】【☆】
F39.72 (2748H)	Cumulative running time of the machine	0~65535 【0H】【☆】
F39.73 (2749H)	Fan cumulative running time	0~65535 【0H】【☆】
F39.74 (274AH)	Cumulative power consumption (high)	0~60000 【0KWH】【☆】 Cumulative power consumption = cumulative power consumption (high) 1000+ cumulative power consumption (low)
F39.75 (274BH)	Cumulative power consumption (low)	0.0~999.9 【0.0KWH】【☆】
F39.76 (274CH)	First failure type	0~99 【0】【☆】 Record the failure type of the previous second failure.
F39.77 (274DH)	The first time it broke down Operating frequency	0~8000 【0Hz】【☆】 Record the operating frequency of the ozone power supply at the time of the previous second failure.
F39.78 (274EH)	The first time it broke down The output current	0.0~6000.0 【0.0A】【☆】 Record the ozone power supply output current at the time of the previous second failure.
F39.79 (274FH)	The first time it broke down Bus voltage	0.0~2500.0 【0.0V】【☆】 Record the DC bus voltage of the ozone power supply at the time of the previous second failure.
F39.80 (2750H)	The first time it broke down The temperature	0.0~125.0 【0.0℃】【☆】 Record the highest temperature (module temperature or radiator temperature) at the time of the previous second failure.
F39.81 (2751H)	The first time it broke down Ozone power supply operation status1 (H)	0000~FFFF 【0000】【☆】 To record the time of the previous second failure Ozone power supply operation status.
F39.82 (2752H)	The first time it broke down Terminal input state (H)	0000~00FF 【0000】【☆】 Record the input status of the ozone power supply terminal at the time of the previous second failure.
F39.83 (2753H)	The first time it broke down Terminal output state (H)	0000~000F 【0000】【☆】 Record the output status of the ozone power supply terminal at the time of the previous second failure.
F39.84 (2754H)	Second failure type	0~99 【0】【☆】 Record the type of failure for the previous failure.
F39.85 (2755H)	From the second malfunction running frequency	0~8000 【0Hz】【☆】 Record the operating frequency of the ozone power supply at the time of the previous failure.

F39.86 (2756H)	Output current in the second fault	0.0~6000.0 【0.0A】【☆☆】 Record the ozone power supply output current at the time of the previous failure.
F39.87 (2757H)	Bus voltage in case of second failure	0.0~2500.0 【0.0V】【☆☆】 Record the DC bus voltage of the ozone power supply at the time of the previous failure.
F39.88 (2758H)	The temperature of the second failure	0.0~125.0 【0.0℃】【☆☆】 Record the maximum temperature (module temperature or radiator temperature) at the time of the previous failure.
F39.89 (2759H)	From the Second Malfunction Ozone power supply operation status1 (H)	0000~FFFF 【0000】【☆☆】 To record the time of the last failure Ozone power supply operation status.
F39.90 (275AH)	Terminal input status in case of second failure(H)	0000~00FF 【0000】【☆☆】 Record the input status of the ozone power supply terminal at the time of the previous failure.
F39.91 (275BH)	Terminal output status in case of Second Failure(H)	0000~000F 【0000】【☆☆】 Record the output status of the ozone power supply terminal at the time of the previous failure.
F39.92 (275CH)	Type of third failure	0~99 【0】【☆☆】 Record the type of fault for the current fault.
F39.93 (275DH)	The operating frequency of the third failure	0~8000 【0Hz】【☆☆】 Record the operating frequency of the ozone power supply at the current time of failure.
F39.94 (275EH)	Output current in the Third Fault	0.0~6000.0 【0.0A】【☆☆】 Record the output current of the ozone power supply at the current time of failure.
F39.95 (275FH)	Bus Voltage at the third fault	0.0~2500.0 【0.0V】【☆☆】 Record the DC bus voltage of the ozone power supply at the current time of failure.
F39.96 (2760H)	The temperature of the third failure	0.0~125.0 【0.0℃】【☆☆】 Record the maximum temperature (module temperature or radiator temperature) at the time of the current failure.
F39.97 (2761H)	The third time it malfunctioned: Ozone power supply operation status1 (H)	0000~FFFF 【0000】【☆☆】 To record the time of the current failure Ozone power supply operation status.
F39.98 (2762H)	Terminal input status in case of third failure (H)	0000~00FF 【0000】【☆☆】 Record the input status of the ozone power supply terminal at the current time of failure.
F39.99 (2763H)	Terminal output status at the third failure (H)	0000~000F 【0000】【☆☆】 Record the output status of the ozone power supply terminal at the current time of failure.

07、Fault diagnosis and exception handling

7.1 Fault phenomena and countermeasures

When the ozone power supply is abnormal, the LED digital tube will display the corresponding fault function code and its content. When the fault relay is running, the ozone power supply will stop output.

The possible failure types of VL1800 and VL2800 series ozone power supply are shown in table 7-1 and table 7-2. In case of ozone power failure, the user shall first check according to this table and record the failure phenomenon in detail. If you need technical services, please contact our after-sales service and technical support department or our local offices and agents.

7.2 Fault record query

This series of ozone power supply has recorded the last three failure codes and operating parameters of the ozone power supply in the event of failure. Query these information to help find the cause of failure.

The fault information is all saved in the F39 group of monitoring parameters. Please enter the F39 group of parameters to inquire the corresponding fault information.

7.3 Fault Reset

In case of ozone power failure, the following operations can be selected to restore normal operation:

- (1) When the fault code is displayed, after confirming that it can be RESET, press the Stop / Reset key.
- (2) After any terminal of X1 ~ X8(F16.00 ~ F16.07) is set as a fault reset signal (No. 7 function), the input terminal can be reset after it is closed with the COM terminal.
- (3) Cut The power and put it back on.



Attention :

- (1) the cause of the failure must be thoroughly checked and removed before resetting, otherwise the ozone power supply may be permanently damaged.
- (2) if the device can not be reset or fails again after the reset, the reason should be checked. Continuous reset will damage the ozone power supply.
- (3) the protection action of overload and overheat should be reset 5 minutes later.

Form 7-1 Alarm code and alarm elimination

Alarm code	alarm instructions	Possible Cause	Solutions
A-10	Warning of ozone power overload	1.Overload 2.Voltage rise time is too short	1. Reduce the load or change to a larger capacity ozone power supply 2. Extend the voltage rise time
A-12	Ozone Power Failure	1. Loose connection of ozone power supply to load	1. Check the load connection and troubleshoot
A-19	Internal data store alarm	1. Read and write function code data process, there is strong interference around 2. Internal memory corruption	1. Retry after reset 2. Seek the services of manufacturers
A-25	External device 1 alarms	1. Ozone power external equipment 1 fault input terminal has signal input	1. Check signal source and related equipment
A-26	External device 2 alarms	1. Ozone power external equipment 2 fault input terminal has signal input	1. Check signal source and related equipment
A-27	External device 3alarms	1. Ozone power external equipment 3 fault input terminal has signal input	1. Check signal source and related equipment
A-28	External device 4 alarms	1. Ozone power external equipment 4 fault input terminal has signal input	1. Check signal source and related equipment
A-29	Warning of disconnection of Keyboard Communication	1.Keyboard to ozone power cord loose	1. Check the wiring from keyboard to ozone power supply
A-30	RS485 Communication break alarm	1. RS485 communication signal break 2. Unreasonable configuration of parameters related to wire breakage detection	1. Check analog input signal wiring and analog input signal source 2. Modify configuration parameters

Form 7-2 Trouble codes and troubleshooting

Fault Code	Fault description	Possible Cause	Solutions
E-01	Overcurrent	1. Voltage rise time set too short 2. Start immediately after output is stopped due to a Fault 3. The power capacity of ozone is on the low side 4. The load end has short circuit or the electrode ignites	1. Adjust voltage rise time 2. Need to troubleshoot before starting 3. Choose the ozone power supply with matching capacity grade 4. Eliminate the source of short circuit or ignition failure
E-02	Overcurrent		
E-03	Overcurrent		
E-04	overvoltage		
E-05	overvoltage	1. Input voltage anomaly 2. Load to ground short circuit	1. Check the input power 2. Short circuit troubleshooting
E-06	overvoltage		
E-07	overvoltage		
E-08	undervoltage	1. Abnormal power supply voltage 2. There is a large load starting in the power grid	1. Check the power supply voltage 2. Separate power supply
E-09	Load overload	1. Voltage rise time set too short 2. Start immediately after output is stopped due to a Fault 3. The power capacity of ozone is on the low side 4. The load end has short circuit or the electrode ignites	1. Adjust voltage rise time 2. Need to troubleshoot before starting 3. Choose the ozone power supply with matching capacity grade 4. Eliminate the source of short circuit or ignition failure
E-10	Ozone Power Supply pre-overload	1. Voltage rise time set too short 2. Start immediately after output is stopped due to a Fault 3. The power capacity of ozone is on the low side 4. The load end has short circuit or the electrode ignites	1. Adjust voltage rise time 2. Need to troubleshoot before starting 3. Choose the ozone power supply with matching capacity grade 4. Eliminate the source of short circuit or ignition failure
E-11	Ozone power overload	1. Overload 2. Voltage rise time is too short 3. High Torque boost voltage or improper V / F Curve Setting 4. Grid Voltage's too low 5. No starting speed tracking and restart function directly starts the rotating load 6. In closed loop vector mode, the encoder pulse direction is opposite to the load direction	1. Reduce the load or replace with a larger capacity ozone power supply 2. Extend the voltage rise time 3. Reduce the torque boost voltage and adjust the V/F curve 4. Check the grid voltage 5. Start/stop mode ([F03.00]) is set as speed tracking restart mode 6. Check whether the encoder is reversed
E-12	Ozone power off	1. Ozone power to load connection loose	1. Check the load wiring and troubleshoot
E-13	Ozone power supply overheating 1	1. Blocked air duct 2. The ambient temperature is too high 3. Abnormal fan 4. Abnormal temperature detection circuit or power module	1. Clear air ducts or improve ventilation conditions 2. Improve ventilation conditions and reduce carrier frequency 3. Replace the fan 4. Seek support from manufacturers
E-14	Ozone Power supply overheating 2	1. Blocked air duct 2. The ambient temperature is too high 3. Abnormal fan 4. Abnormal temperature detection circuit or power module	1. Clear air ducts or improve ventilation conditions 2. Improve ventilation conditions and reduce carrier frequency 3. Replace the fan 4. Seek support from manufacturers
E-15	Current detection error	1. The current sensor is damaged	1. Replace Current Sensor
E-16	Power module failure	1. The load current is too high 2. Power module damaged	1. Reduce the load or change to a larger capacity ozone power supply 2. Replace the power module
E-17	Load tuning failure	1. The load is not connected when the load parameter is identified	1. The load is not connected when the load parameter is identified.

Fault Code	Fault description	Possible Cause	Solutions
E-18	CPU fault	1. CPU damage 2. Abnormal interference	1. Seek manufacturer's Service
E-19	Internal data storage error	1. In the process of reading and writing functional code data, there is strong interference around. 2. Internal memory damage	1. Retry after reset 2. Seek the services of manufacturers
E-20	Parameter copy error	1. In the process of reading and writing functional code data, there is strong interference around. 2. Internal memory damage	1. Retry after reset 2. Seek the services of manufacturers
E-21	Run limit time reached	1. The time limit for operation has expired.	Please contact your direct supplier
E-22	Phase is missing on the input side	1. The lead from the power grid to the ozone power supply is broken 2. The three-phase voltage imbalance ratio is large	1. Eliminate peripheral failures 2. Add AC or DC reactor
E-23	Phase missing on the output side Or the output current is unbalanced	1. The lead from ozone power supply to load is broken. 2. Ozone power driver board or control board failure. 3. Load three-phase Winding Fault.	1. Eliminate peripheral failures 2. Seek support from manufacturers 3. Troubleshoot load failures
E-24	Output to Ground Short Circuit Fault	1. Ozone power output short circuit to the ground 2. Load three-phase winding short-circuit to the ground	1. Troubleshoot peripheral faults 2. Troubleshoot load failures
E-25	External Equipment 1 Failure	1. The ozone power peripheral equipment 1 fault input terminal has the SIGNAL INPUT.	1. Check signal source and related equipment
E-26	External Equipment 2 Failure	1. Ozone power peripheral equipment 2 fault input terminal has signal input.	1. Check signal source and related equipment
E-27	External Equipment 3 Failure	1. Ozone Power Peripheral Equipment 3 FAULT INPUT TERMINAL HAS SIGNAL INPUT	1. Check signal source and related equipment
E-28	External Equipment 4 Failure	1. Ozone Power Peripheral Equipment 4 FAULT INPUT TERMINAL HAS SIGNAL INPUT	1. Check signal source and related equipment
E-29	Keyboard communication failure	1. Loose wiring from keyboard to ozone power supply	1. Check the wiring from keyboard to ozone power supply
E-30	RS485Communication failures	1. RS485 communication signal break 2. Unreasonable configuration of parameters related to wire breakage detection	1. Check analog input signal wiring, analog input signal source 2. Modify configuration parameters
E-44	The current was detected to be faulty	1. Voltage rise time set too short 2. Start immediately after output is stopped due to a Fault 3. The power capacity of ozone is on the low side 4. The load end has short circuit or the electrode ignites 5. The setting of current detection parameters is not reasonable	1. Adjust voltage rise time 2. Need to troubleshoot before starting 3. Choose the ozone power supply with matching capacity grade 4. Eliminate the source of short circuit or ignition failure 5. Modification of current detection parameters
E-45	retention	retention	retention
E-99	Voltage correction fault	—	—

08、 Maintenance and upkeep.

The changes of operating environment, such as temperature, humidity, smoke, and the aging of the internal components of ozone power supply, may lead to various failures of ozone power supply. Therefore, in the storage, use of the ozone power must be routine inspection, and regular maintenance.

Form 8-1 Check content regularly

Check items	Check content	Exception handling
Main Circuit Terminal, Control Circuit Terminal Screw	If the screws are loose	Tighten with a screwdriver
cooling fin	If there's any dust	Blow it off with dry compressed air at 4 ~ 6kgcm2 pressure
PCB printed circuit board	If there's any dust	Blow it off with dry compressed air at 4 ~ 6kgcm2 pressure
cooling fan	Whether there is abnormal sound, abnormal vibration, the cumulative time running up to 20,000 hours.	Replace cooling fan
power component	If there's any dust	Blow it off with dry compressed air at 4 ~ 6kgcm2 pressure
aluminum electrolytic capacitor	Discoloration, odor, bubbling	Replace the aluminum electrolytic capacitor

8.1Daily maintenance

When the ozone power supply is turned on normally, please confirm the following:

- (1) whether the temperature of the ozone power supply is abnormal.
- (2) whether the ambient temperature is too high.
- (3) whether the load ammeter is the same as usual.
- (4) whether the cooling fan of ozone power supply is in normal operation.

8.2 Regular maintenance and upkeep

8.2.1Regular Maintenance

When the ozone power regularly maintenance inspection, first must cut off the power supply, to monitor no display and the main circuit power indicator lights off, before the inspection. The contents of the check are shown in Table 8-1.

8.2.2 Regular upkeep

In order to make the ozone power supply work normally for a long time, it is necessary to carry out regular maintenance for the service life of the electronic components inside the ozone power supply.The service life of the electronic components of ozone power source is different because of the different environment and service conditions.As shown in Table 8-2 ozone power supply maintenance period for user reference only.

Form 8-2 Ozone Power Supply Component Replacement Time

Part Name	Standard Replacement Years
Cooling Fan	2 ~ 3 YEARS
electrolytic condenser	4~5 YEARS
Printed Circuit Board	5~8 YEARS
Fuse	10 YEARS

The above ozone power supply parts replacement time of the use of the conditions:

- (1) ambient temperature: 30 ° C annual average.
- (2) load factor: less than 80% .
- (3) running time: less than 12 hours per day.

8.3 Warranty of Ozone Power Supply

The company will provide warranty service in the following situations:

- (1) the warranty only refers to the ozone power supply itself;
- (2) In normal use, the company is responsible for the warranty of ozone power supply failure or damage within 12 months after the date of delivery. Reasonable maintenance costs will be charged after 12 months;
- (3) A maintenance fee shall also be charged within 12 months if:
 - Do Not Follow the operating procedures of the Operation Manual, resulting in ozone power supply damage;
 - Ozone power supply damage caused by flood, fire, abnormal voltage or force majeure;
 - Ozone power supply damage caused by wrong connection wire;
 - Damage caused by using ozone power supply for abnormal functions;
- (4) The relevant service costs are calculated on the basis of actual costs. If there is a contract, it shall be dealt with according to the principle of contract priority.

09、 Revision History

The information version number is recorded in the lower right corner of the back cover of this information.

Issue Year / Month	Version number	Project Content	Change Content
July 2015	V1.0		Release Of the First Edition
May 2016	V1.1	Chapter 5	Modify some of the default settings
May 2017	V1.2	Chapter 5	Increase current detection function



VOLO(Shanghai) transmission system co., LTD

Service Hotline (CHINA): 4008 203 007

fax: 021-68183057

Web Page: www.sh-volo.com

Address : Building 7, Kangqiao Advanced
Manufacturing Technology Innovation Park, 2388
Xiupu road, Pudong New Area, Shanghai

